

Synthetic Biology for Organic Learning



A. Malcolm Campbell
Biology and **GCAT**

Laurie J. Heyer
Mathematics and **GCAT**



Todd T. Eckdahl
Biology and **GCAT**

Jeff L. Poet
Mathematics and **GCAT**

ASMCUE
June 3, 2011

Outline of Presentation

1. Introduce synthetic biology
2. Applications of synthetic biology
3. Synthetic biology research at Davidson College
4. Why make biological computers?
5. How do we prepare undergraduates for SynBio?

What is Synthetic Biology?

Implementation of engineering principles and mathematical modeling to the design and construction of biological parts, devices, and systems with applications in energy, medicine, and technology.

www.bio.davidson.edu/projects/gcat/Synthetic/What_Is_SynBio.html

Synthetic Biology: Win-Win

Win #1: your design functions as expected.

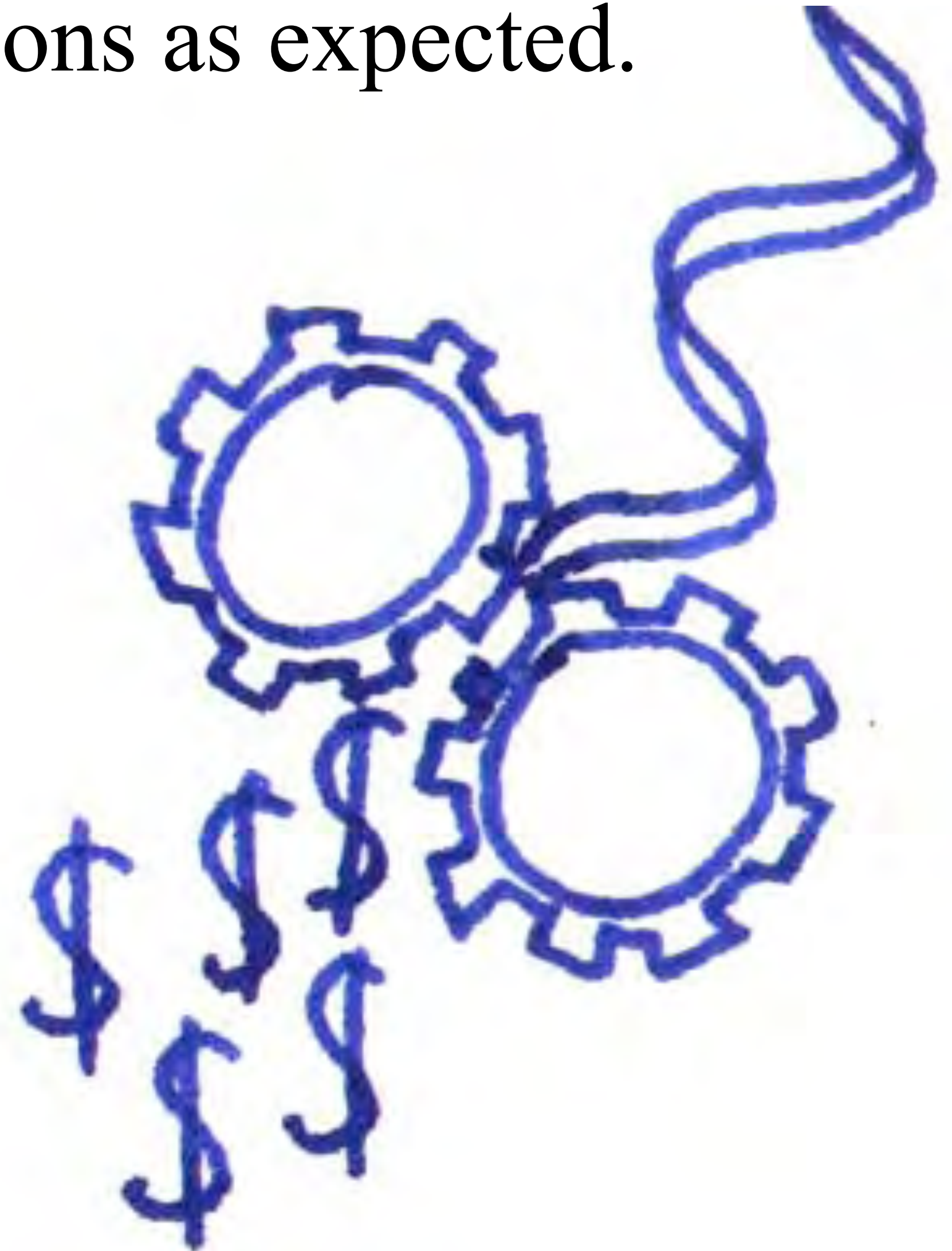

Synthetic Biology: Win-Win Research



Win #1: your design functions as expected.

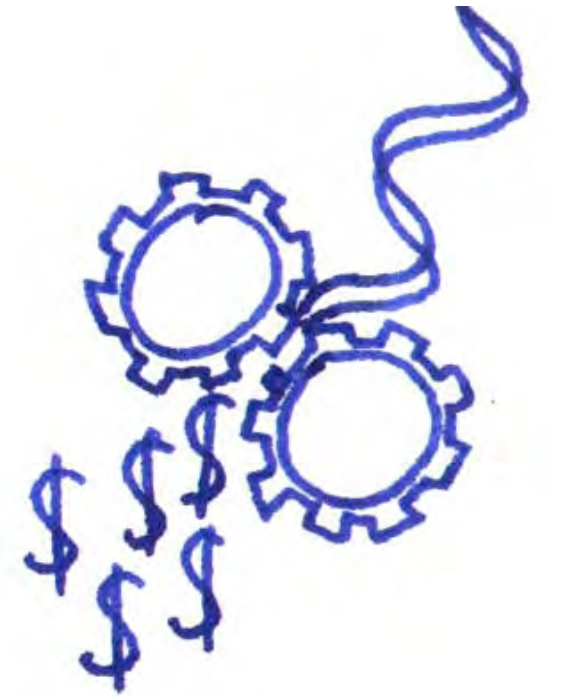

Win #2: your design fails but you uncover basic biology

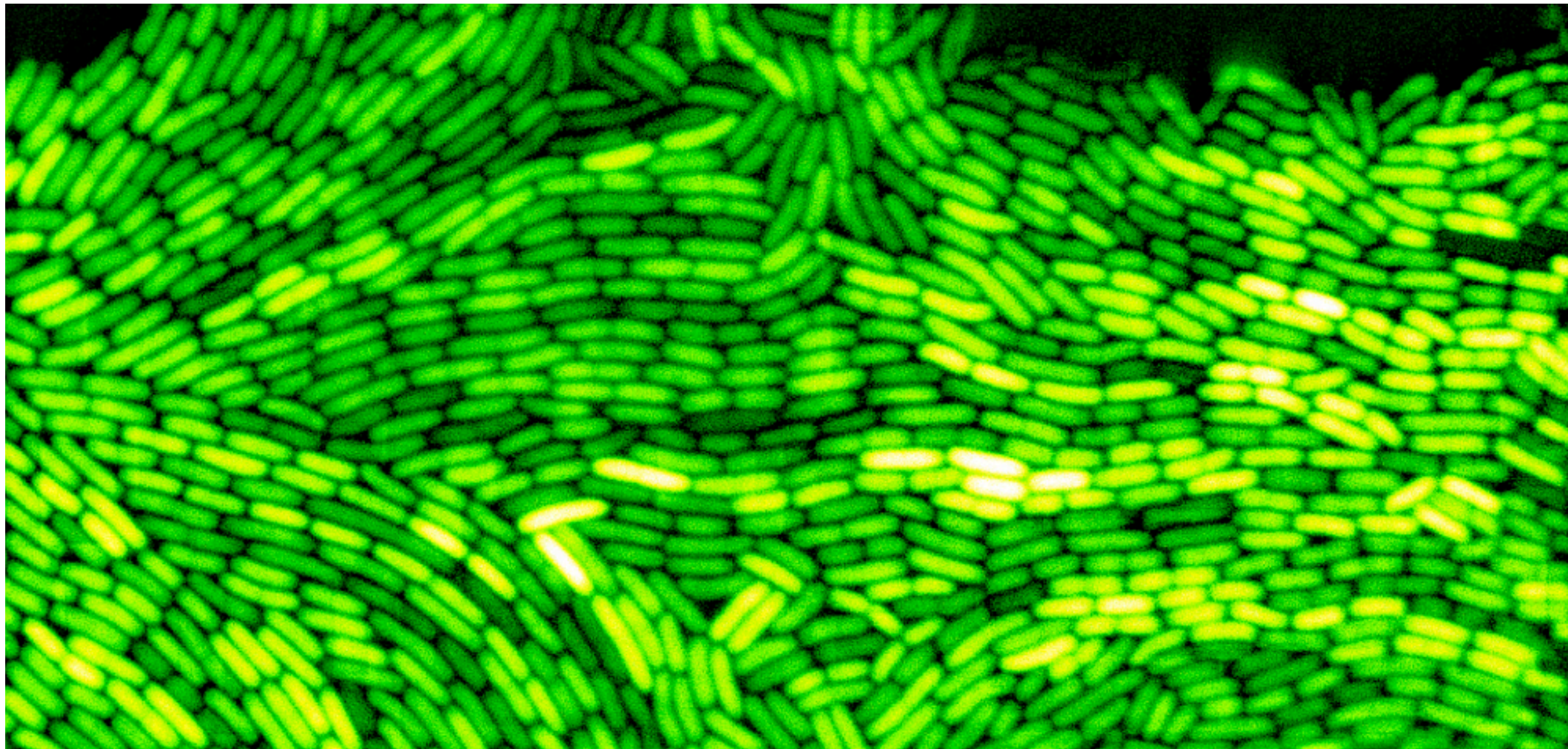

How is Synthetic Biology Different?

Abstraction

Modularity

Standards

Designing and modeling

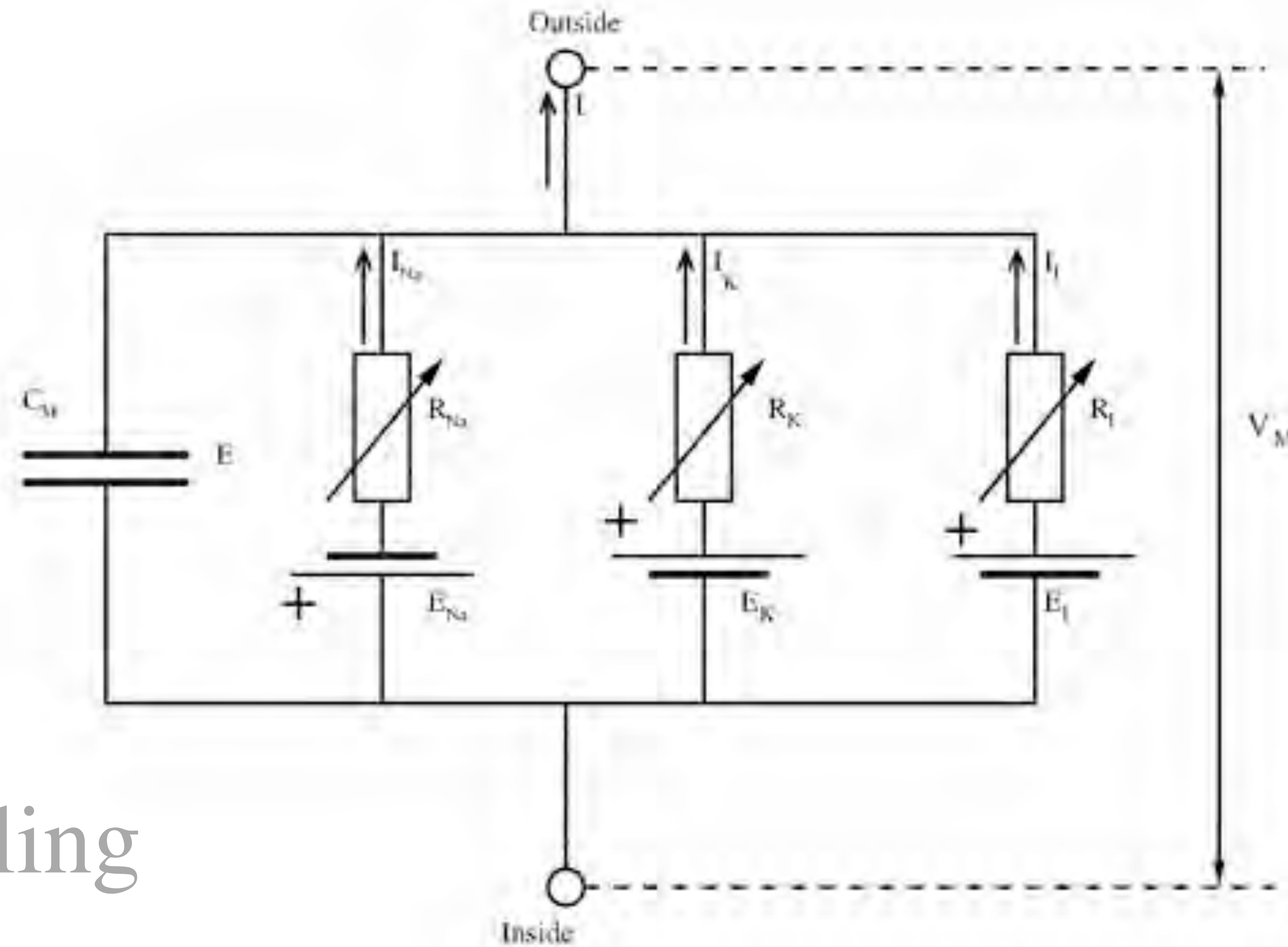

How is Synthetic Biology Different?

Abstraction

Modularity

Standards

Designing and modeling

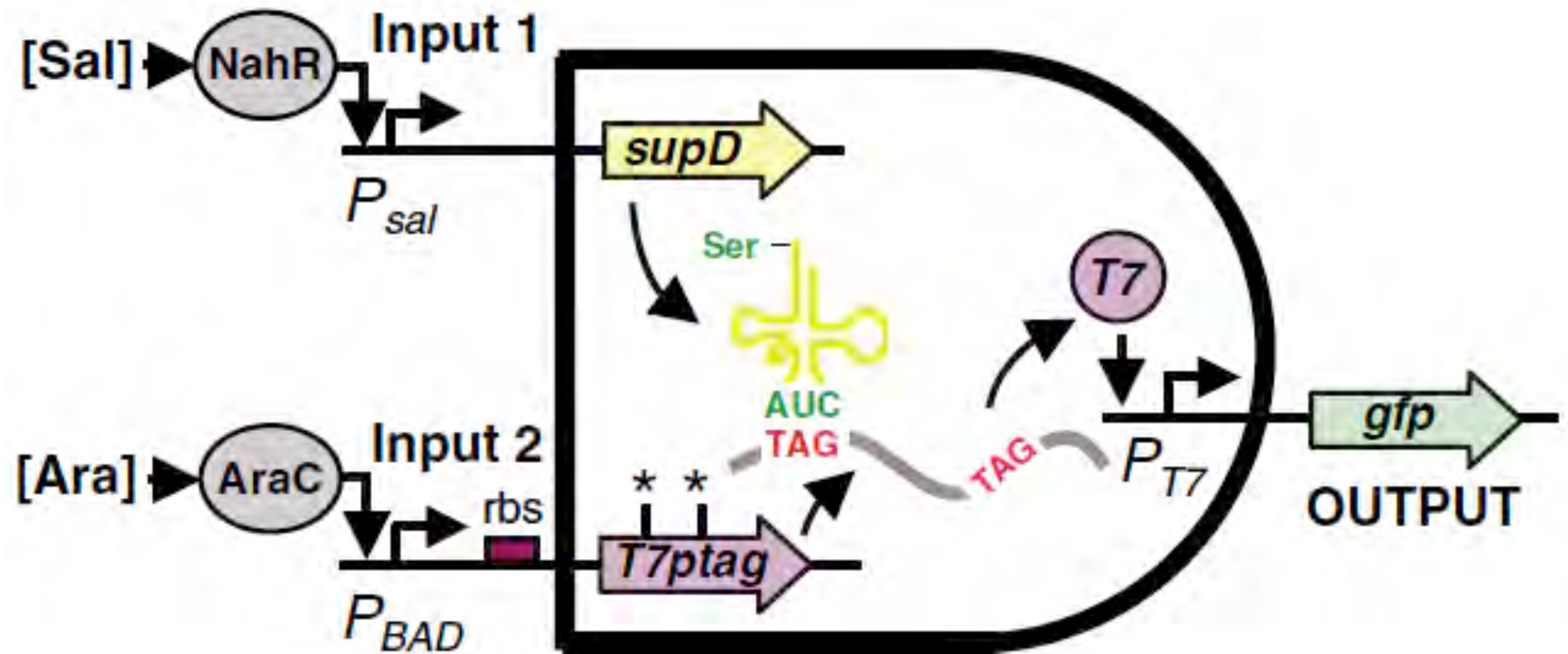

AND Logic Gate

How is Synthetic Biology Different?

Abstraction

Modularity

Standards

Designing and modeling

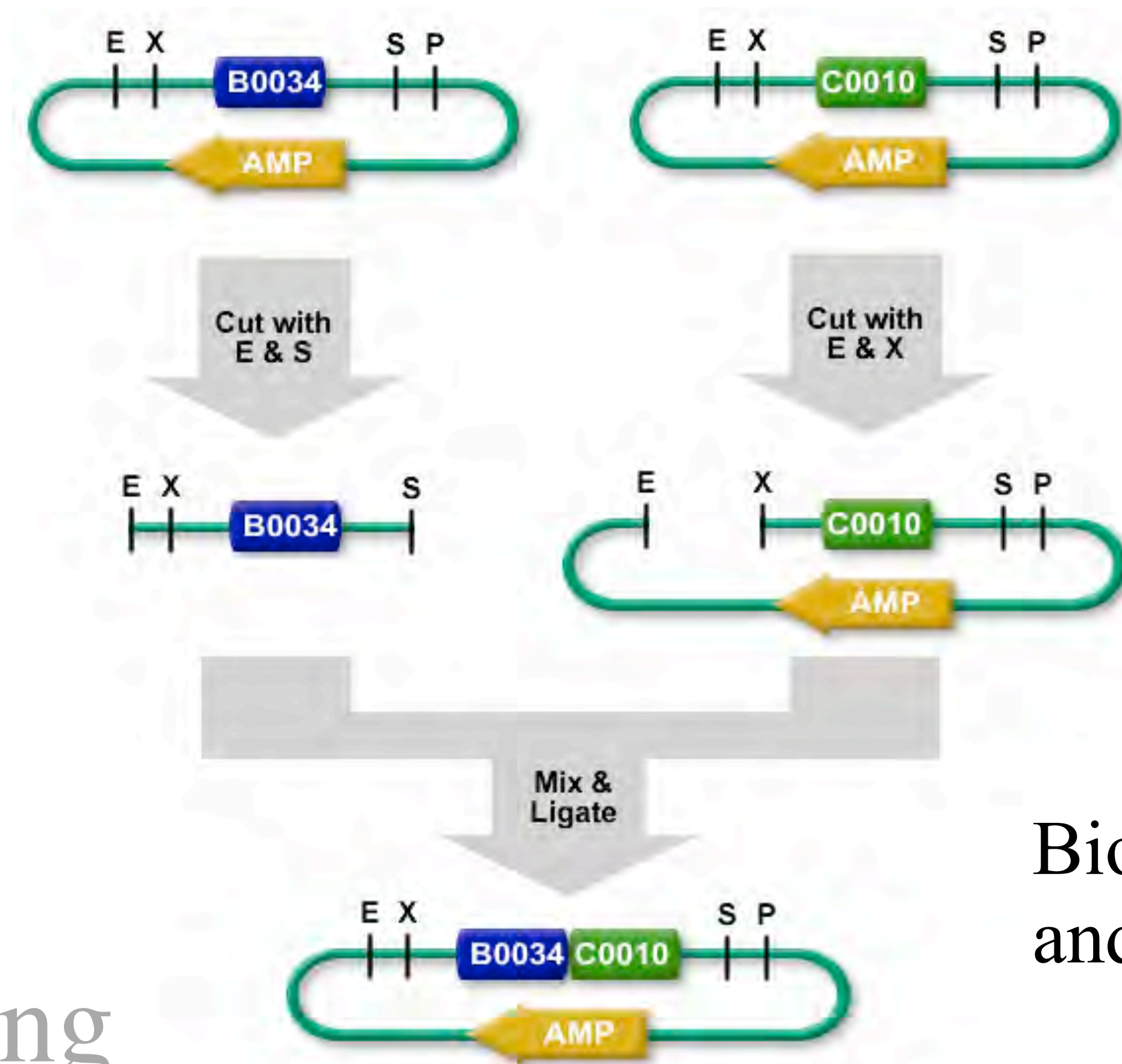

BioBrick Ends
and Ligation

How is Synthetic Biology Different?

Abstraction

Modularity

Standards

Designing and modeling

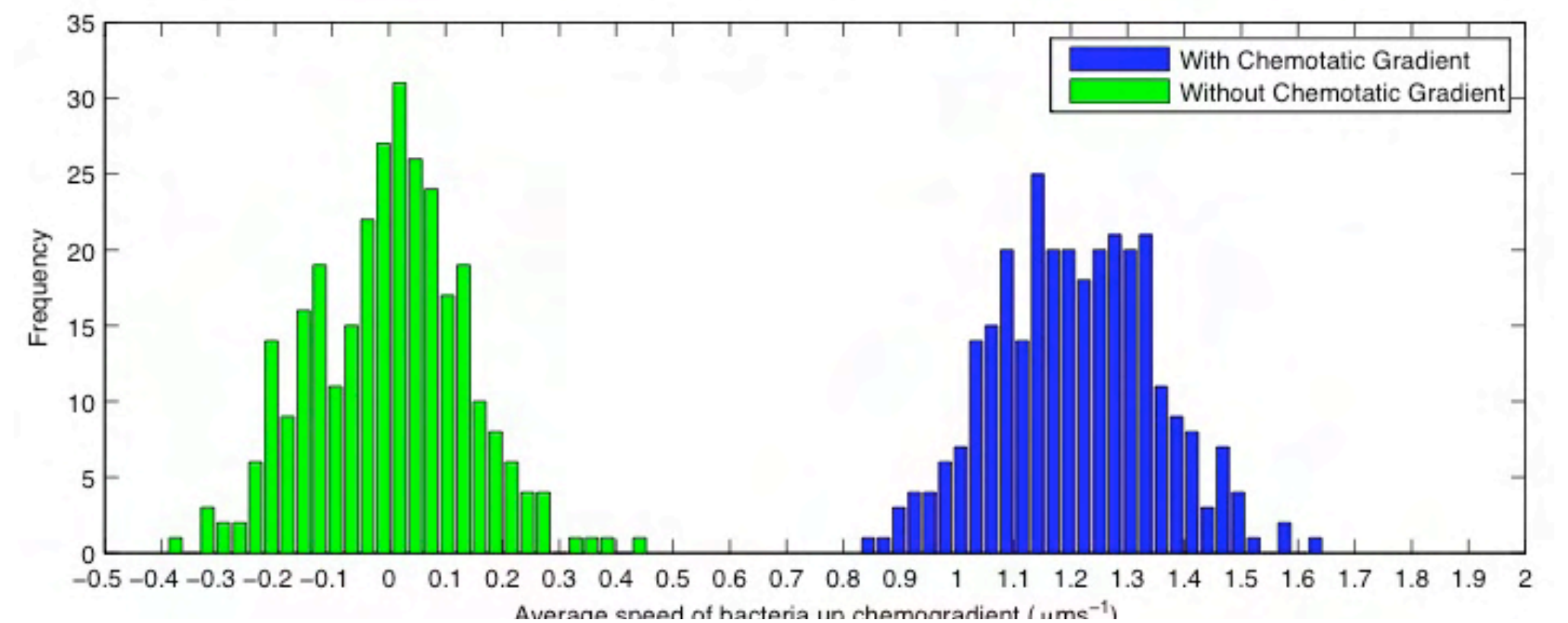
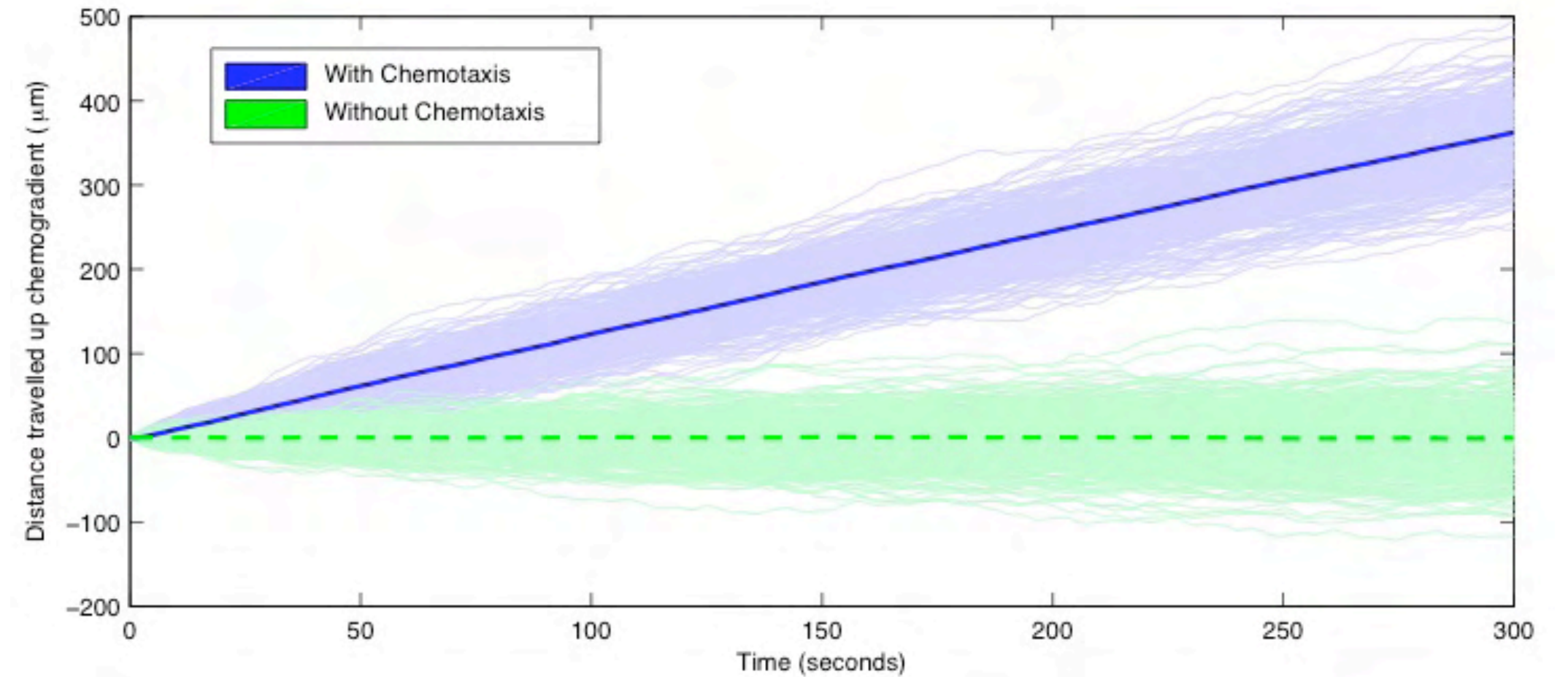

What is iGEM?



at a glance:

1925 minutes of talks	77 presentations
1200 participants	24 awards
825 jamboree attendees	22 weeks of work
84 teams	21 countries

http://2009.igem.org/Main_Page

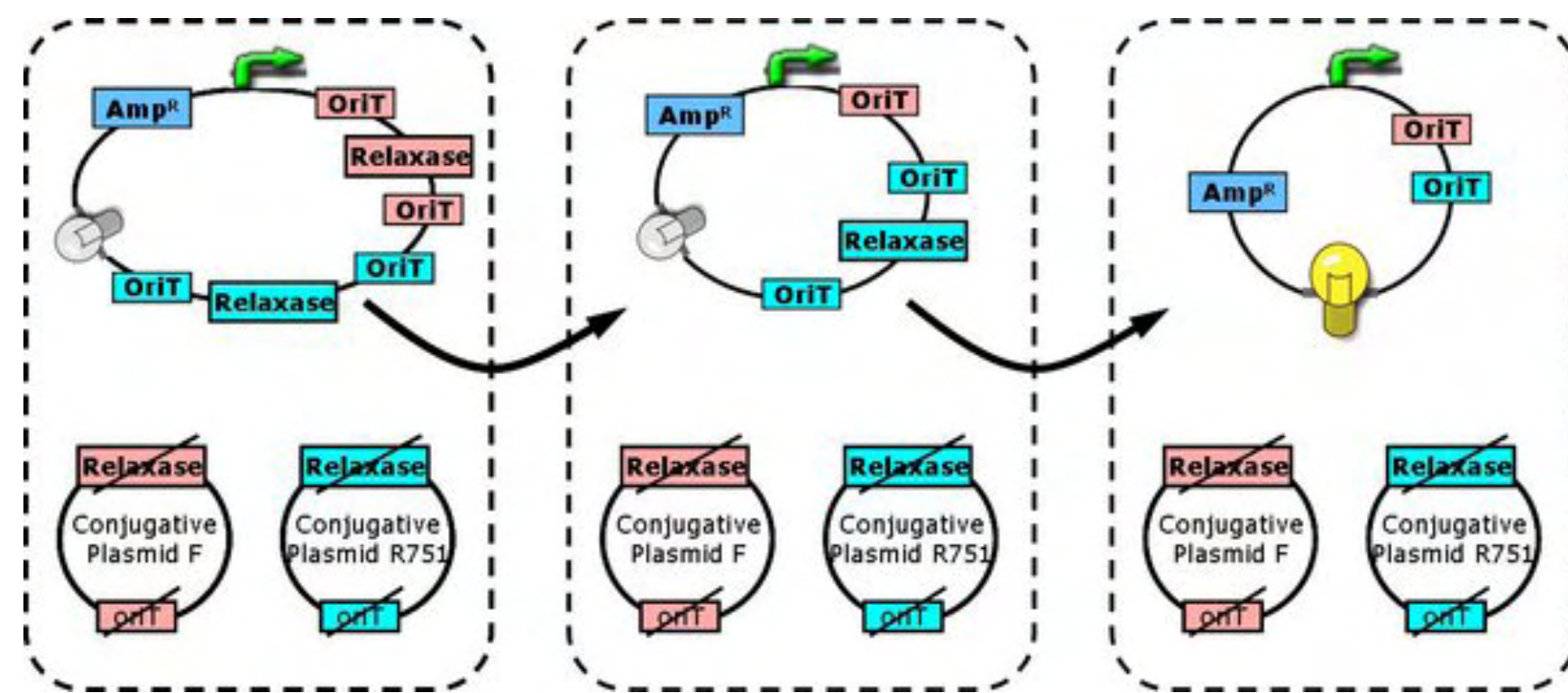

Peking University

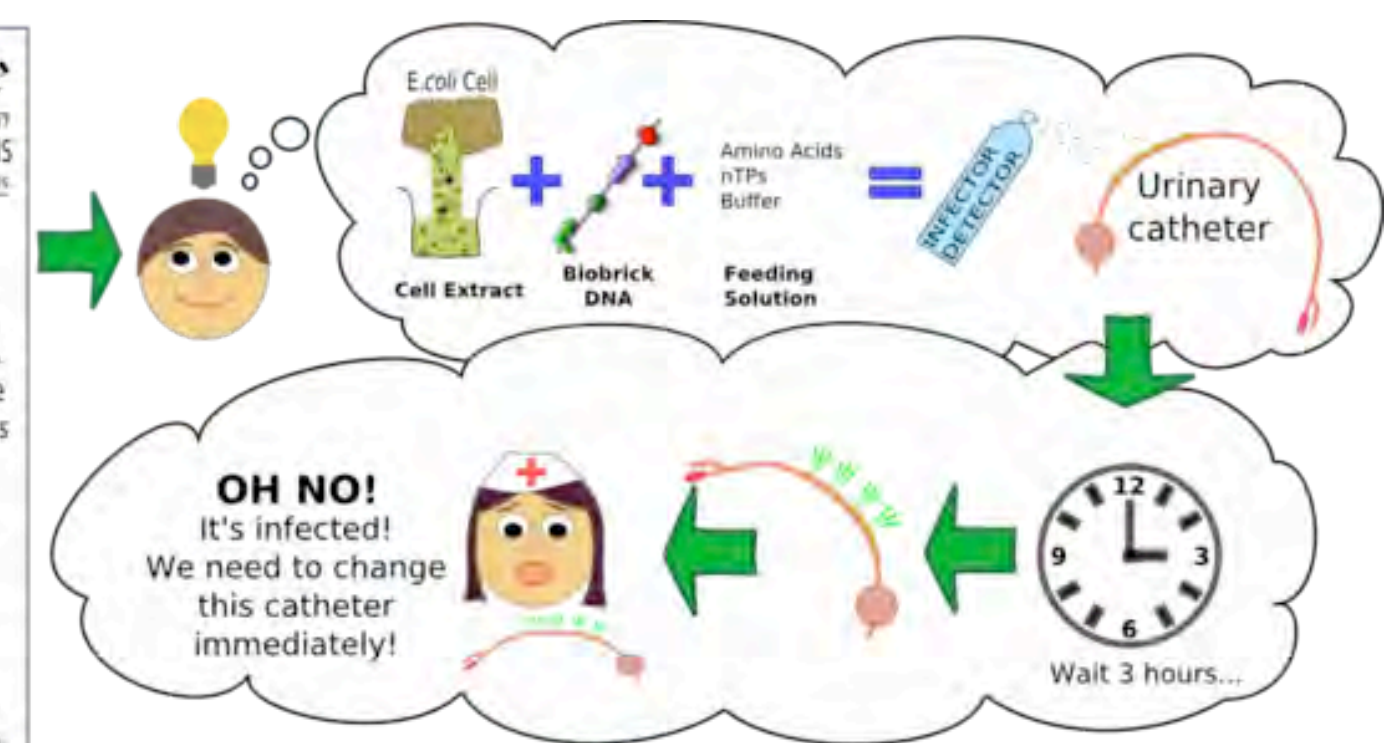

Imperial College

Standardized and Modular DNA

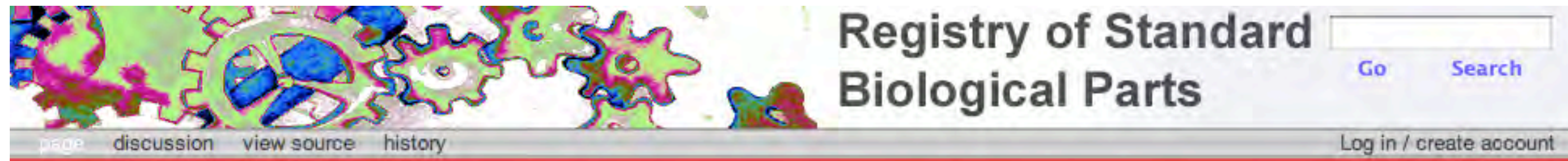

Welcome to the Registry of Standard Biological Parts.

The Registry is a collection of ~3200 genetic parts that can be mixed and matched to build synthetic biology devices and systems. Founded in 2003 at MIT, the Registry is part of the Synthetic Biology community's efforts to make biology easier to engineer. It provides a resource of available genetic parts to [IGEM](#) teams and academic labs.

The Registry is based on the principle of "get some, give some". Registry users benefit from using the parts and information available from the Registry in designing their engineered biological systems. In exchange, the expectation is that Registry users will, in turn, contribute back information and data on existing parts and new parts that they make to grow and improve this community resource.



[Catalog of parts & devices](#)



[Help](#)



[Users & groups](#)
(Apply for an account)



[DNA repositories](#)

Registry tools

- [Search parts \(?\)](#)
- [Add a part](#)
- [Request a part](#)
- [Send parts to the Registry](#)
- [Sequence analysis](#)



You'll notice some significant changes to the Registry recently. In particular, the Registry [catalog of parts](#) has been entirely redesigned to allow for easier browsing of the available parts and devices. You can now browse parts and devices by type, by function, by chassis and by standard. You'll also notice that the documentation and help pages for each class of parts have been greatly enhanced.

The Registry of Standard Biological Parts is *always* a work in progress. Please browse the new catalog and let us know what you think, or feel free to edit and improve the pages further.

Real World Applications of Synthetic Biology

Land Mine Detection

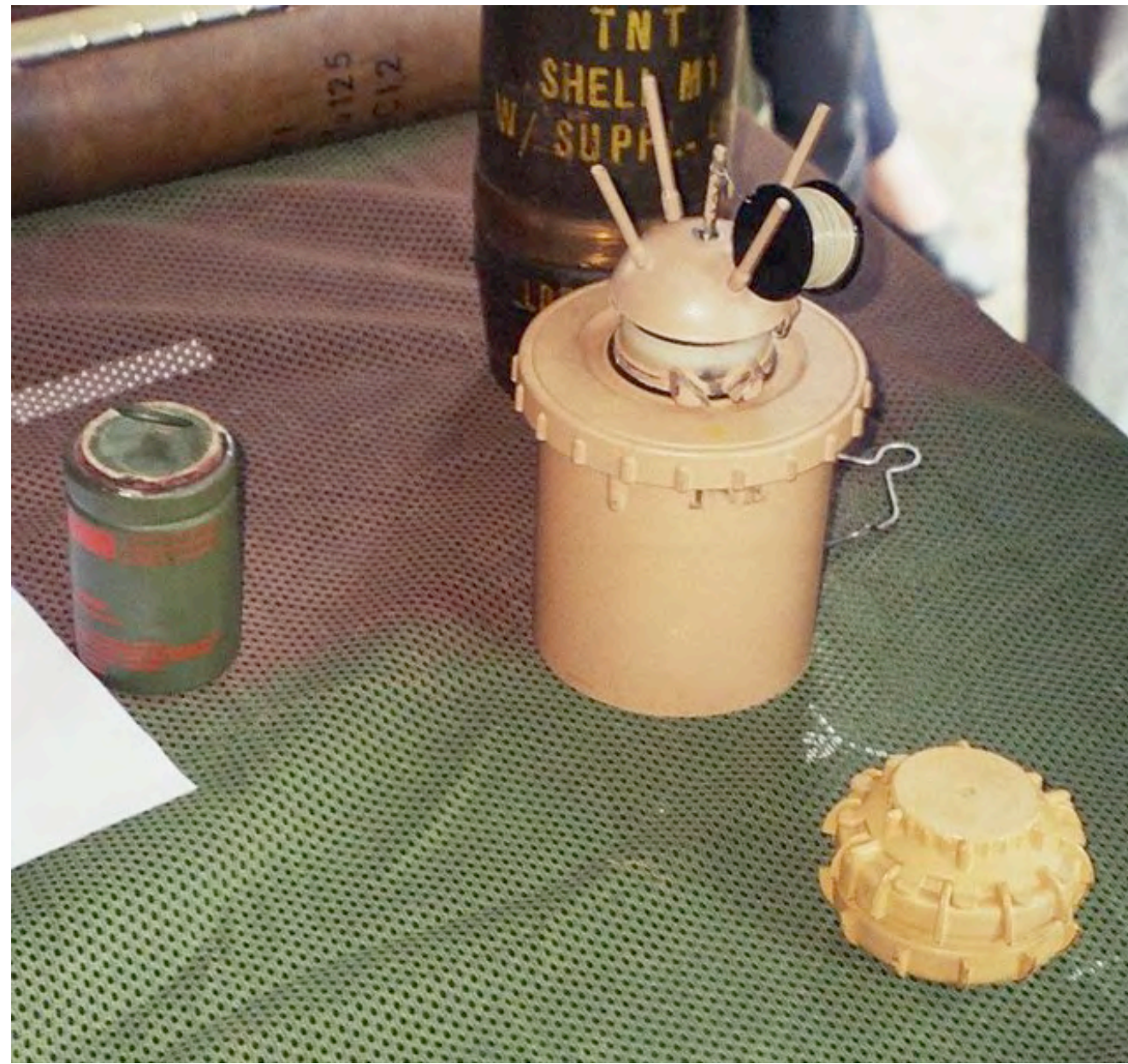

Land Mine Detection



Synthetic Biology Land Mine Detection



WARNING SIGN: The bioengineered Thales cress turns red when exposed to a mine byproduct.

COURTESY OF ARESA
BIODETECTION

New weed may flag land mines

By John K. Borchardt | *Contributor to The Christian Science Monitor*

Synthetic Biology

Land Mine Detection



WARNING SIGN: The bioengineered Thales cress turns red when exposed to a mine byproduct.

COURTESY OF ARESA BIODETECTION

New weed may flag land mines

By John K. Borchardt | *Contributor to The Christian Science Monitor*

Production of Medicines

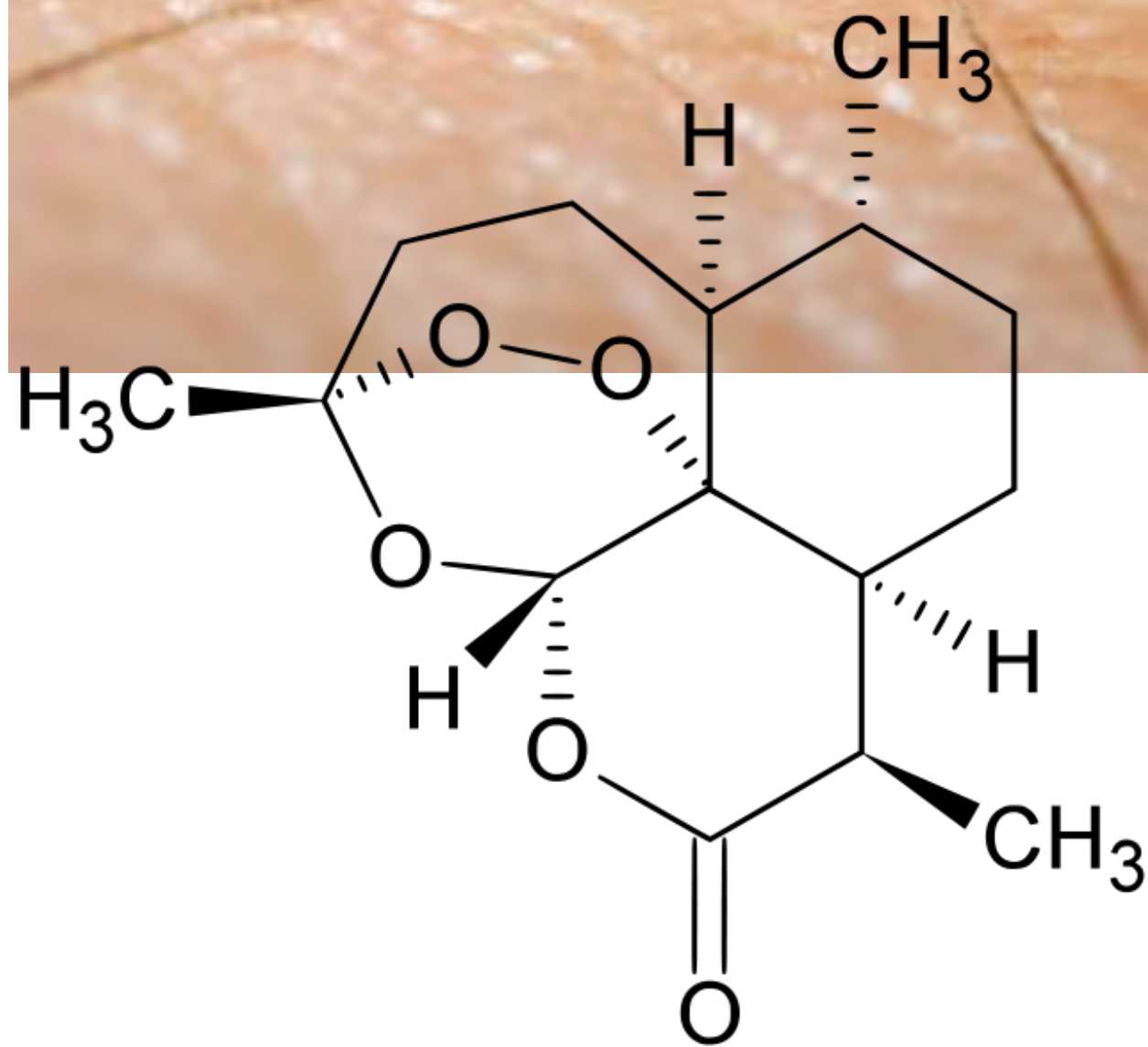
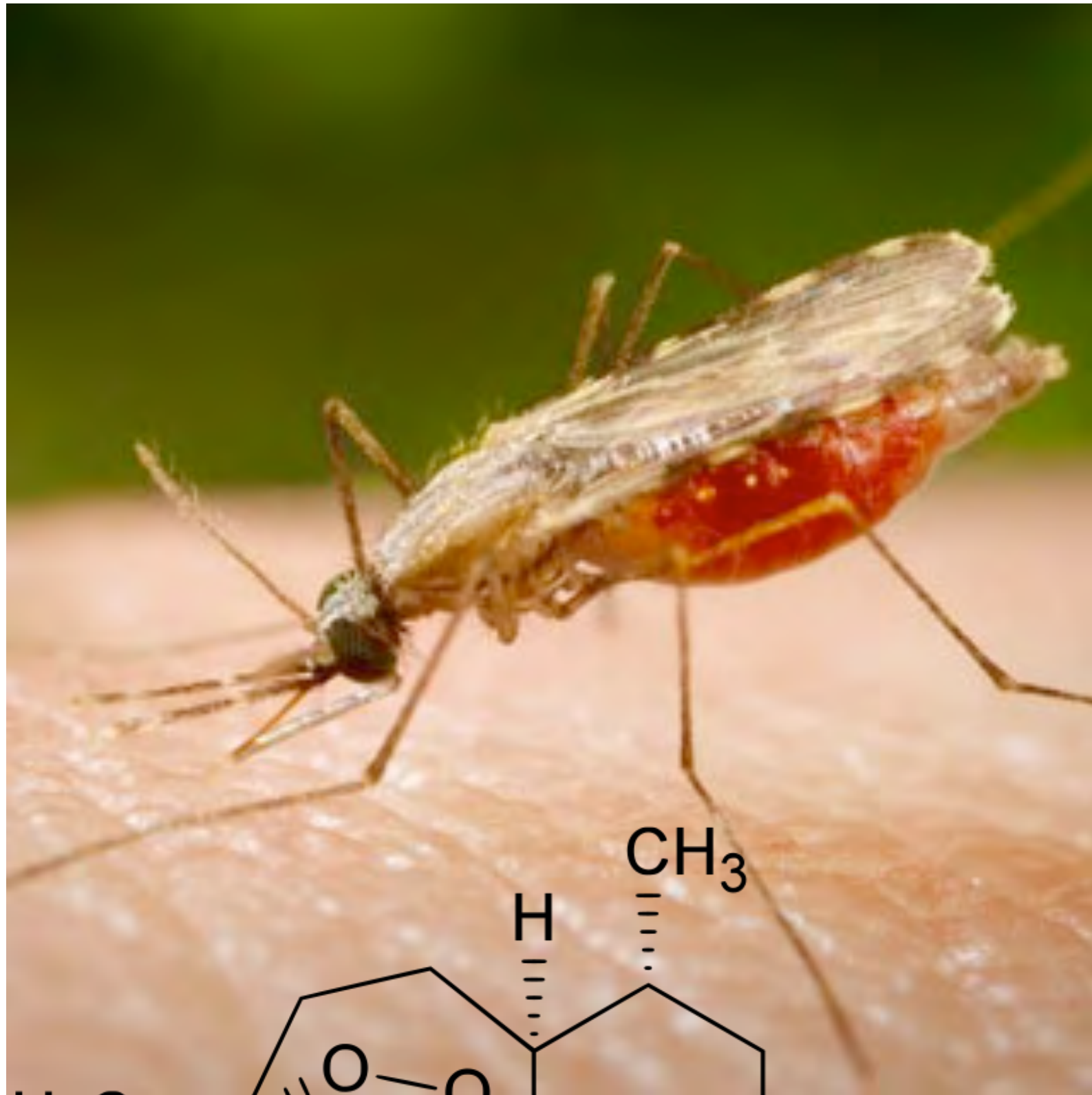

\$1 per pill

Production of Medicines

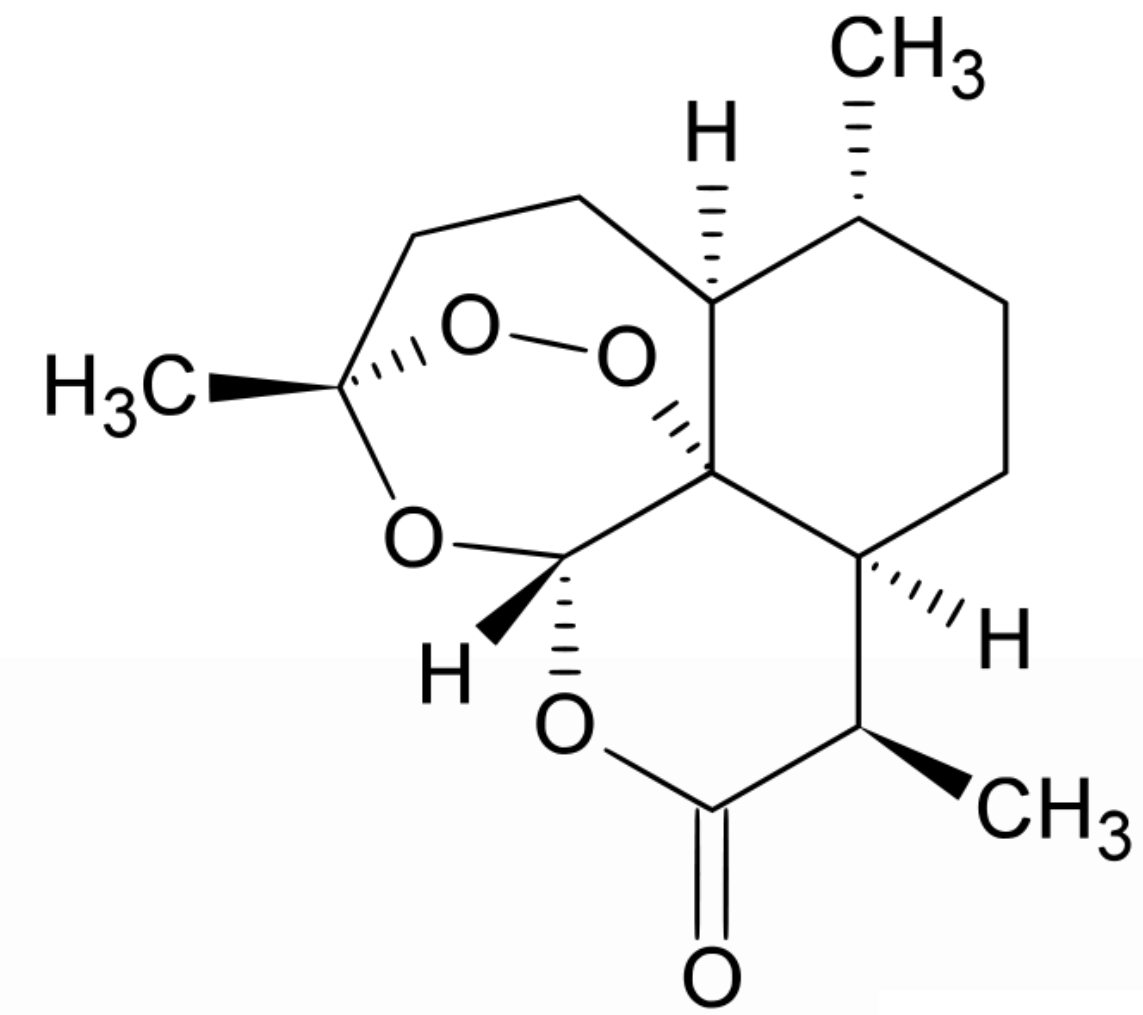

10¢ per pill

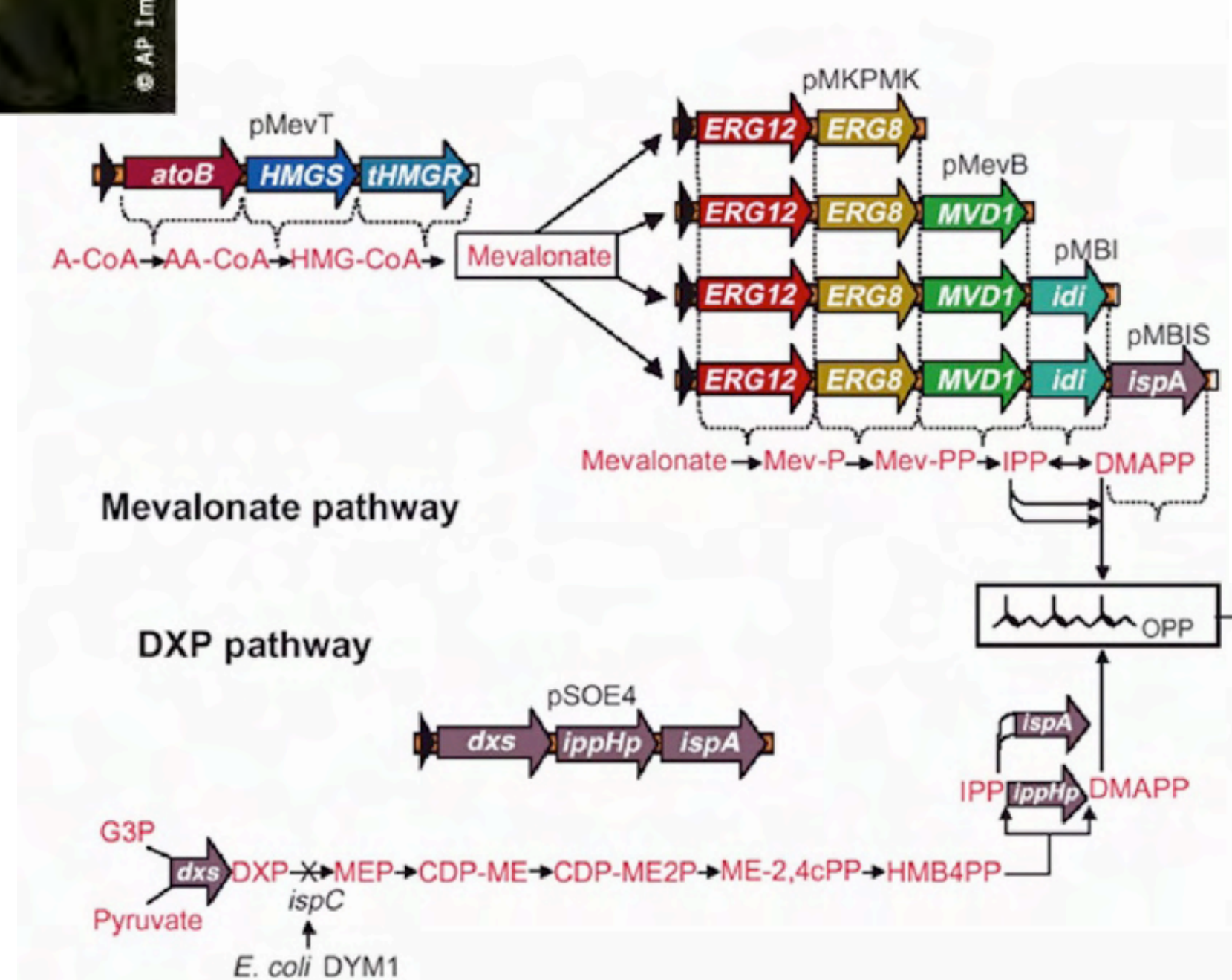

Biofuels from Algae

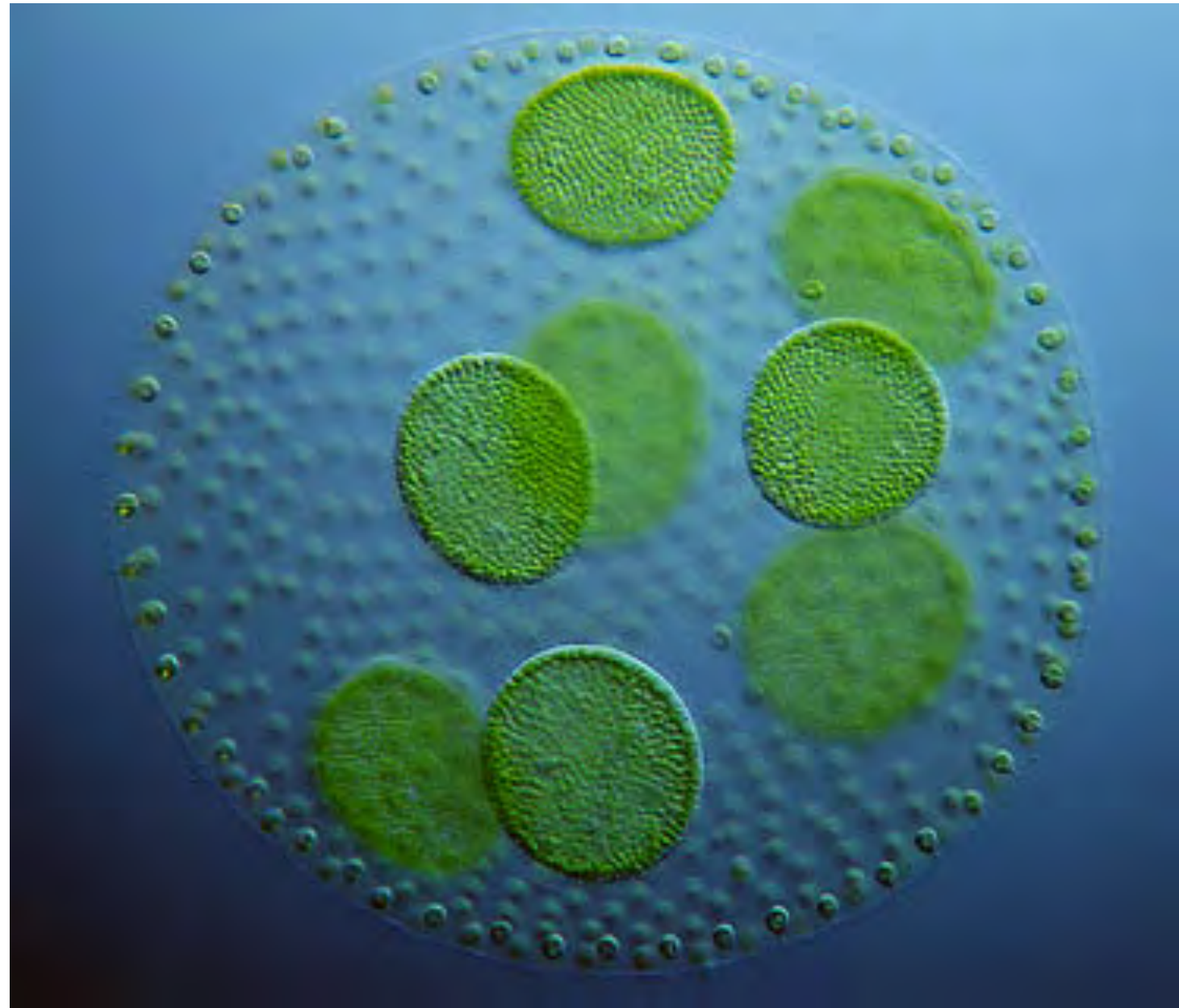

CO₂-neutral
1,000,000 gallons in 2008

Synthetic Biology at Davidson College



Building Bacterial Computers



Advantages of Bacterial Computation

Software → Hardware → Computation



Computation



Computation

<http://www.dnamnd.med.usyd.edu.au/>

<http://www.turbosquid.com>

Advantages of Bacterial Computation

Software → Hardware → Computation



Computation



Computation

<http://www.dnamnd.med.usyd.edu.au/>

<http://www.turbosquid.com>

Advantages of Biological Computers

go anywhere - arctic, thermal vents, inside organisms

no electricity

self-replicating

no immune rejection



Self-replicating Computers

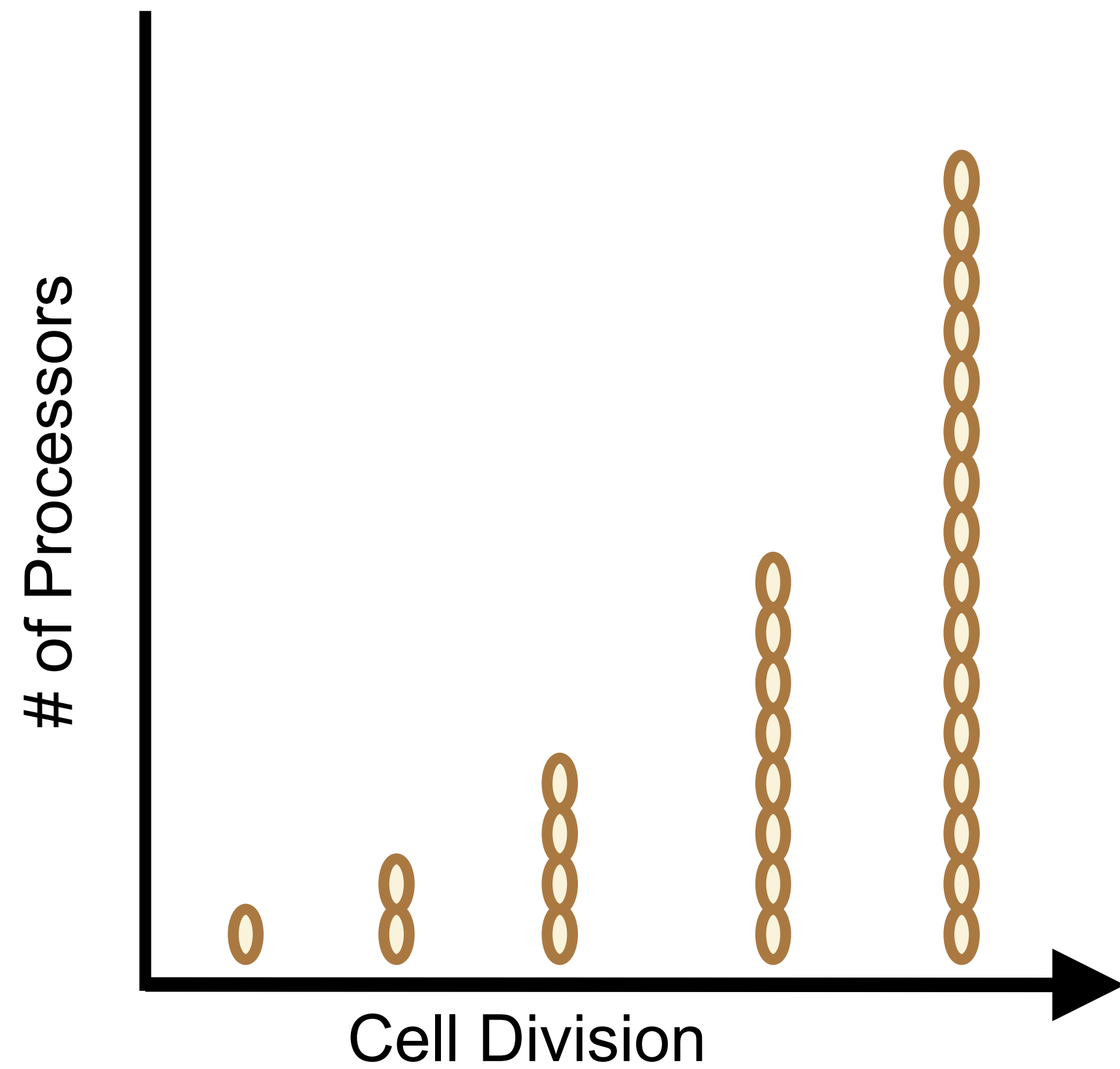
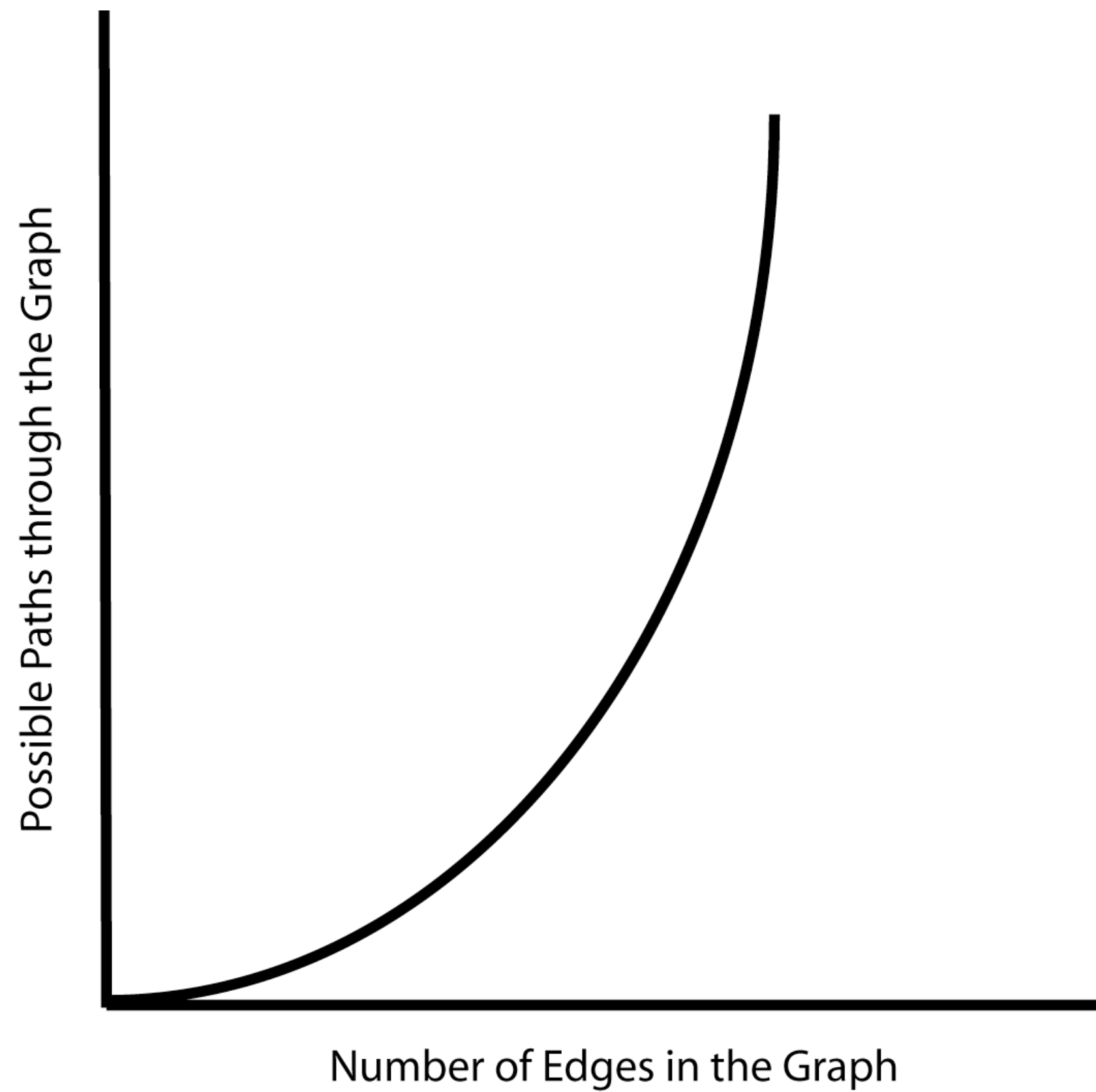

Two Undergraduate Research Projects

Burnt Pancake Problem



Burnt Pancake Problem

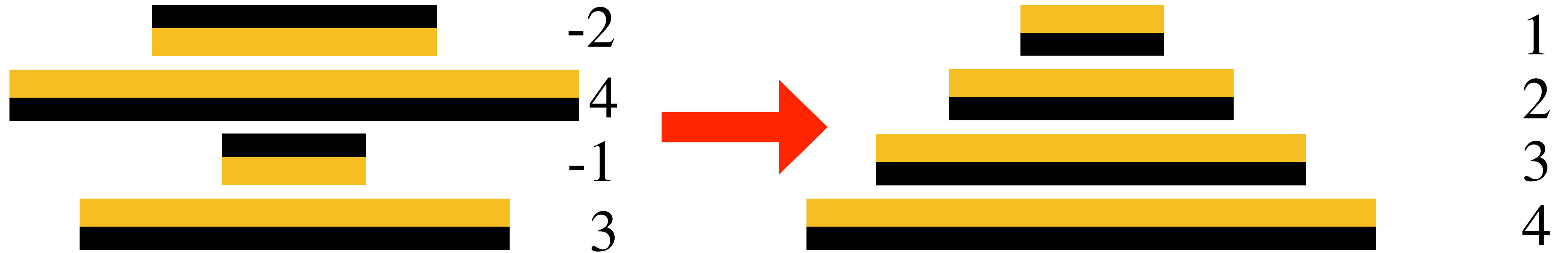

Burnt Pancake Problem

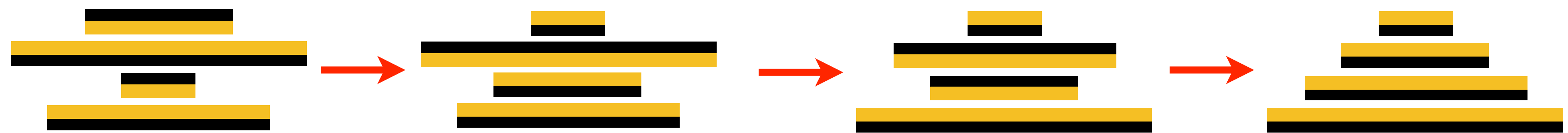
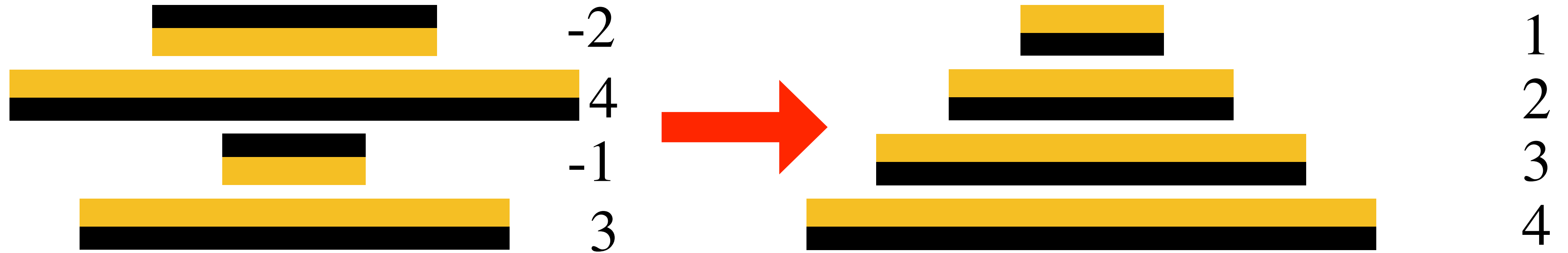

DNA Burnt Pancakes

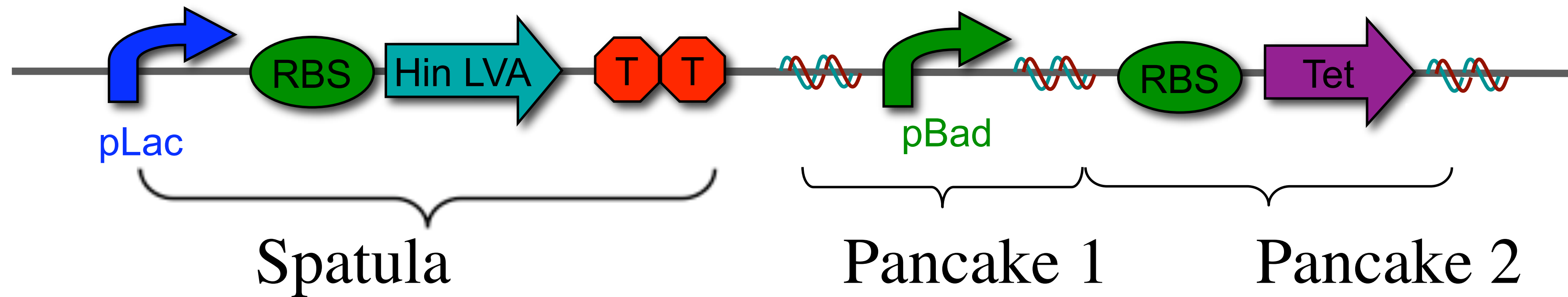

abstractions of DNA parts

Flipping DNA with Hin/*hixC*

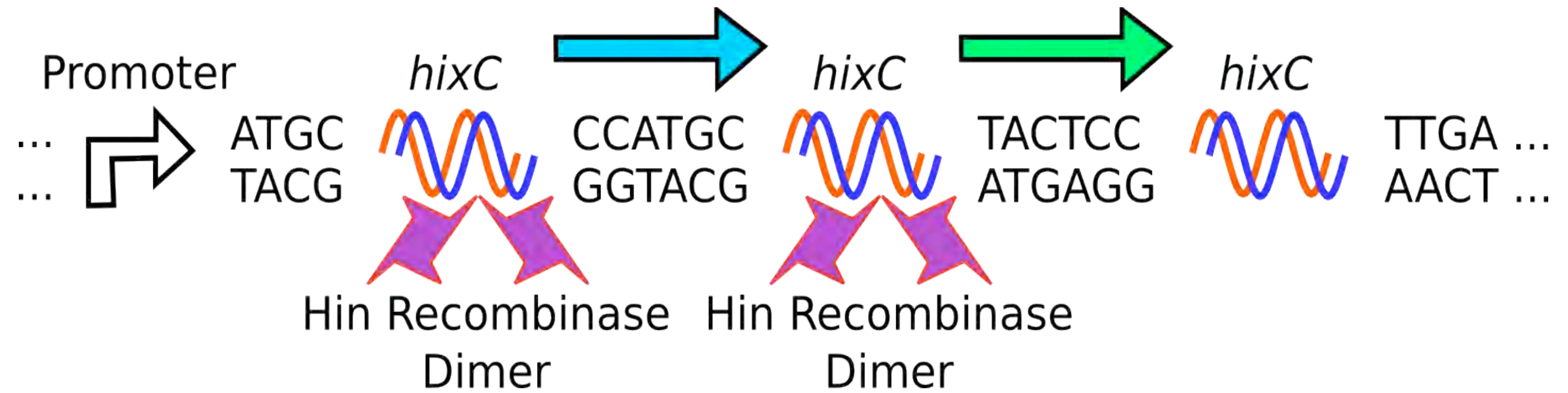

Flipping DNA with Hin/*hixC*

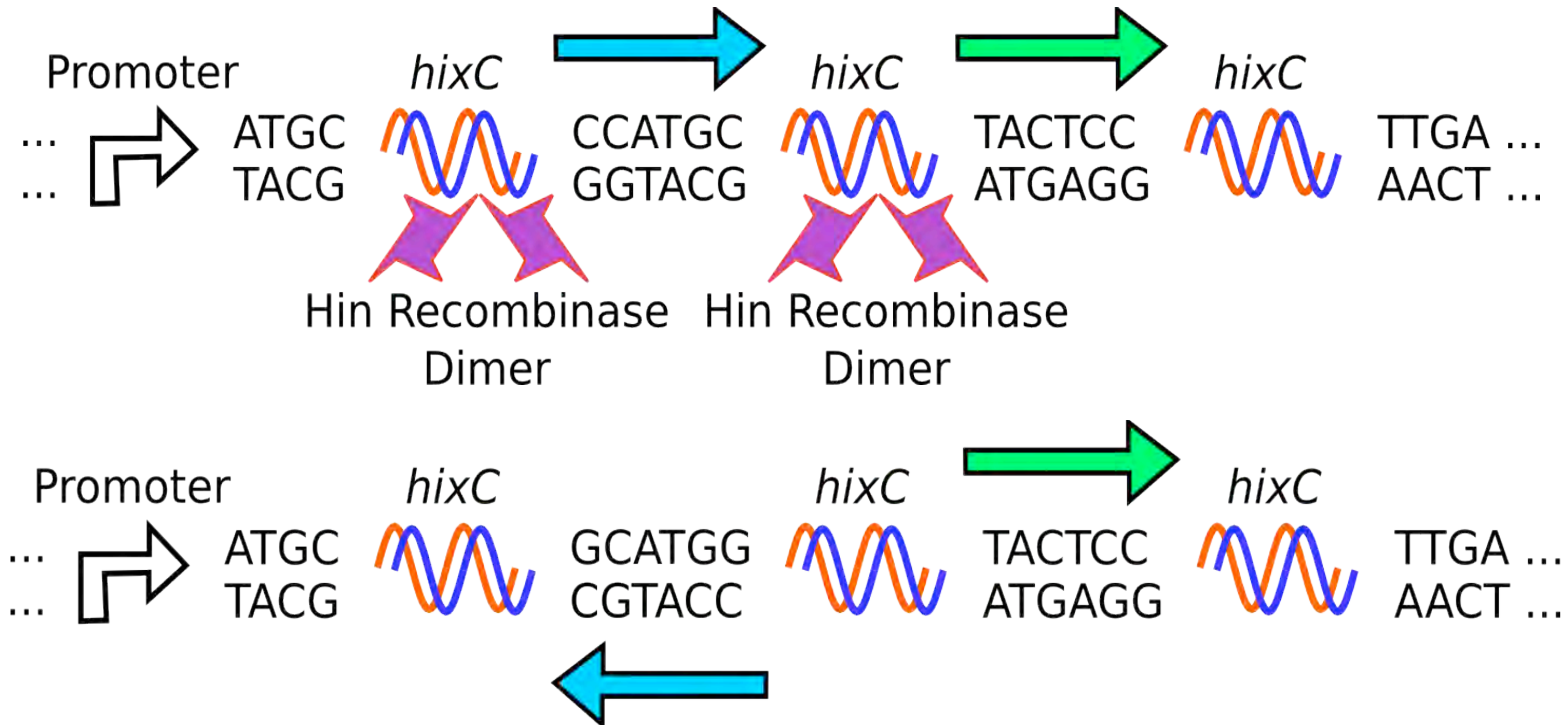

Flipping DNA with Hin/*hixC*

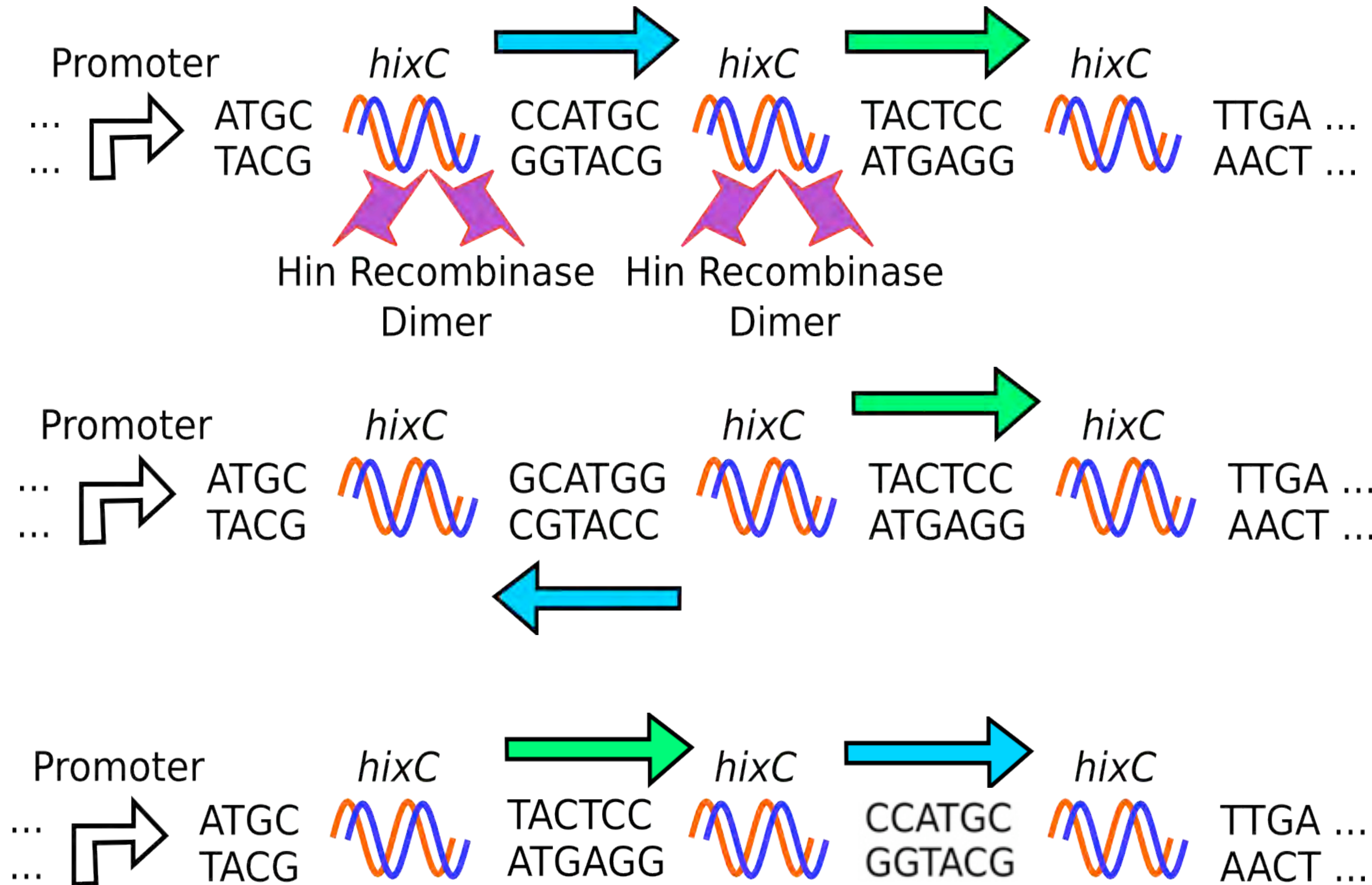

DNA Burnt Pancakes

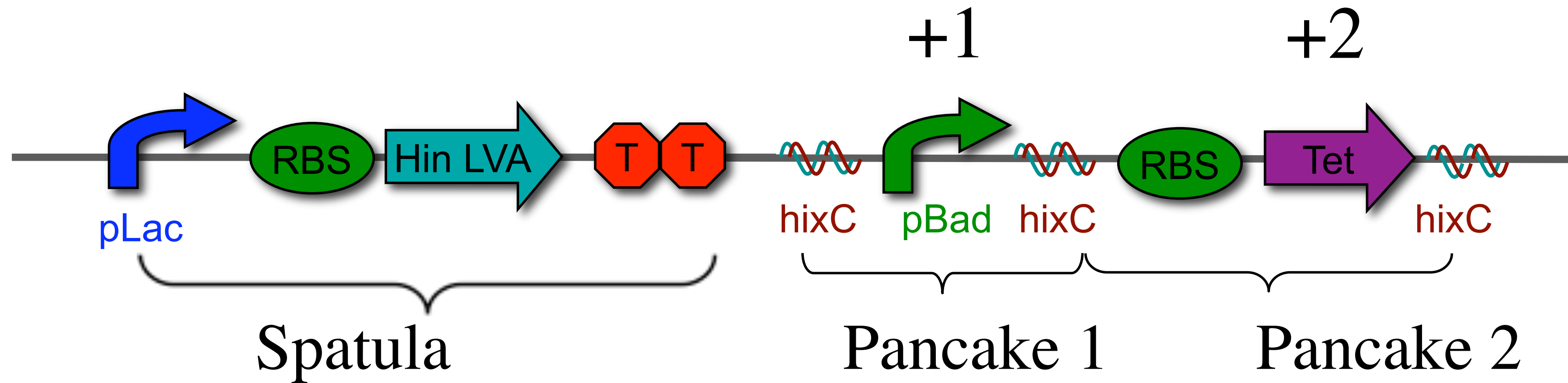

convert to signed numbers

DNA Burnt Pancakes

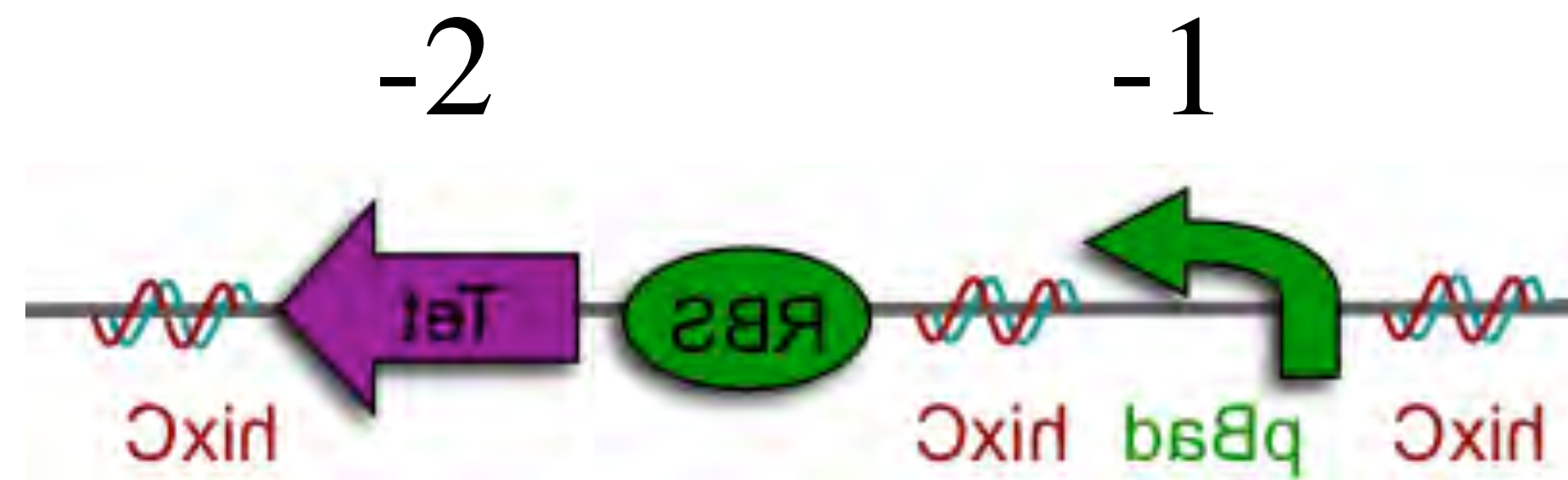
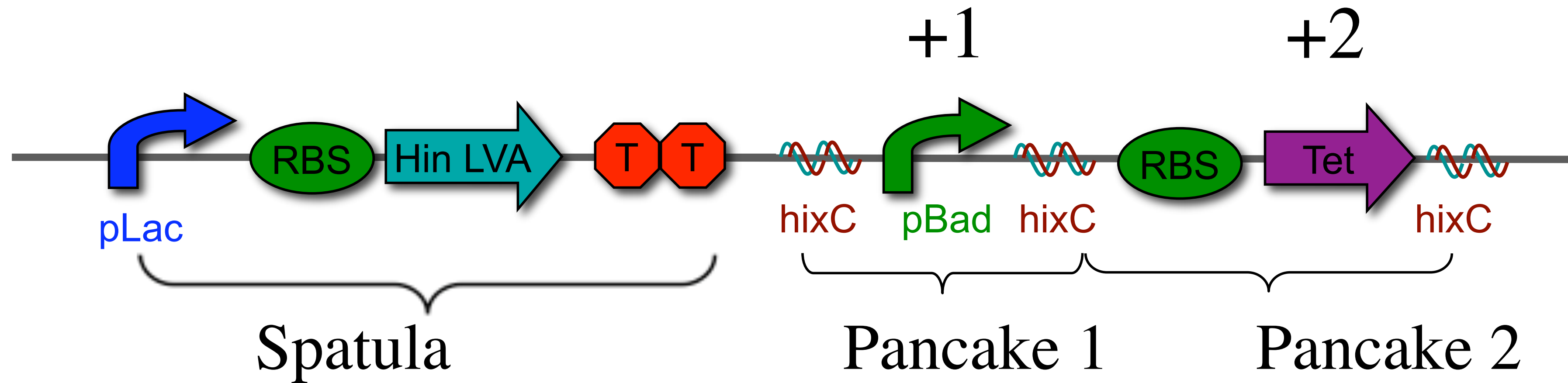

biologically equivalent
mathematically distinct

Modeling Burnt Pancakes

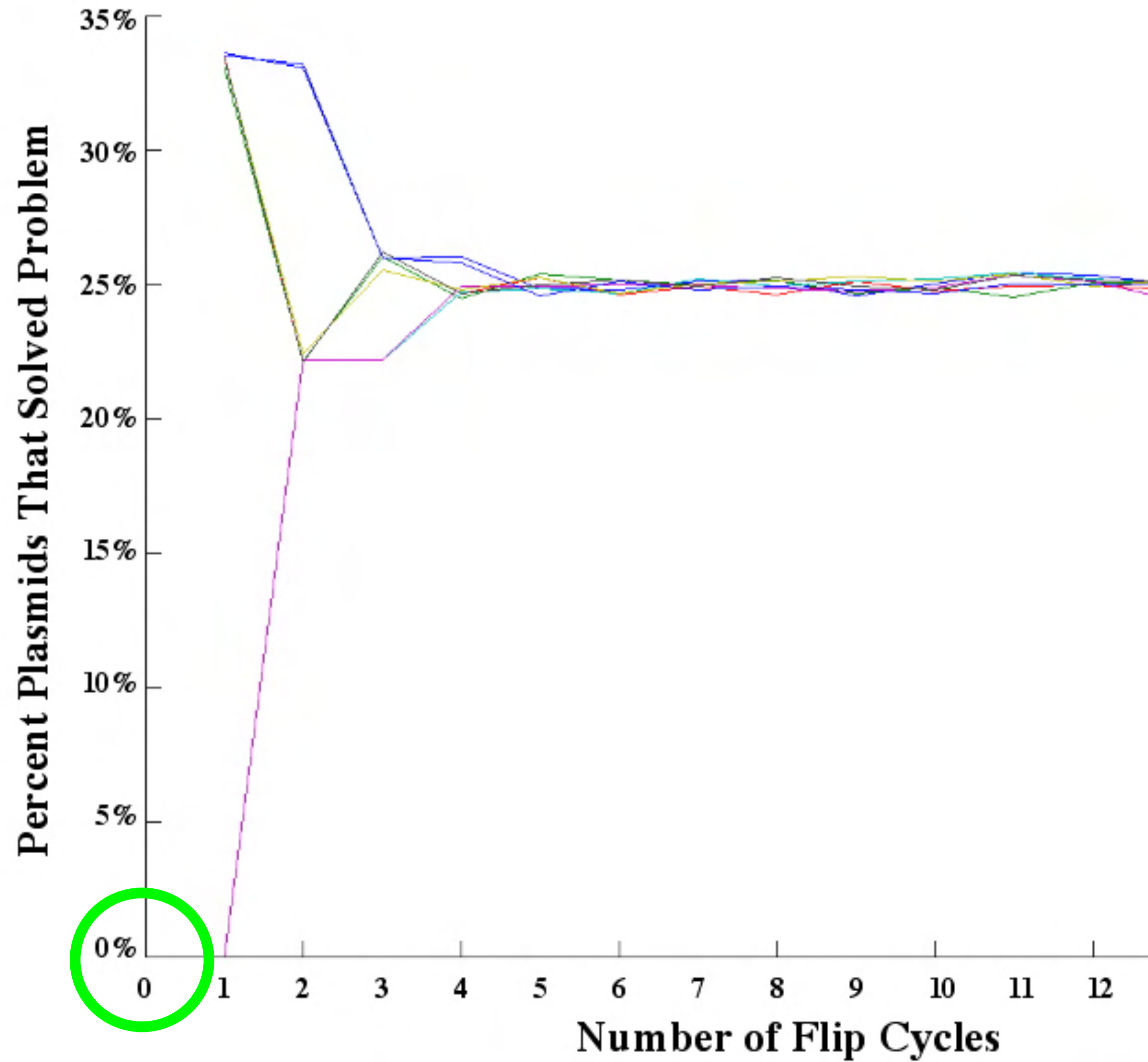
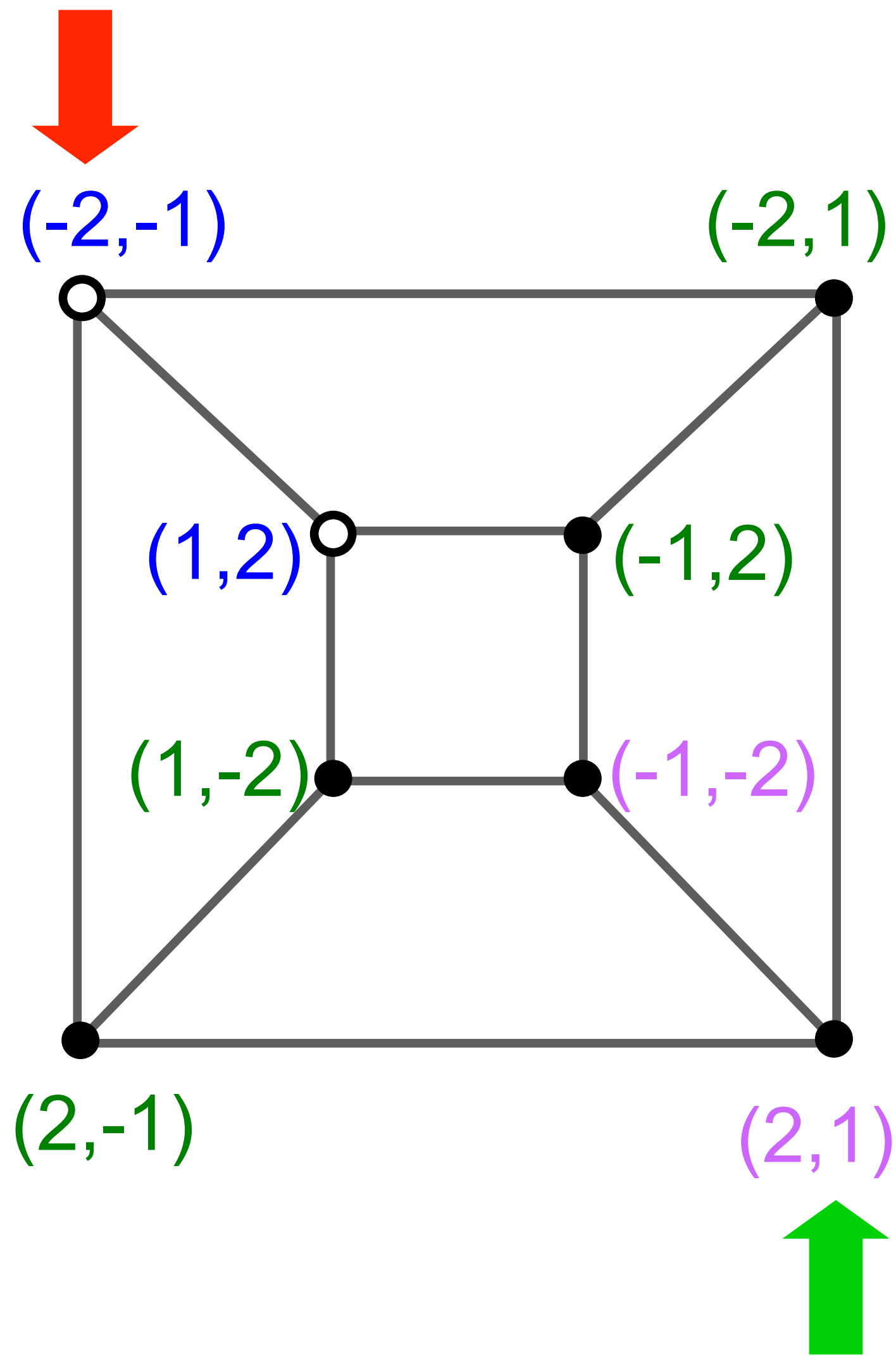

Modeling Burnt Pancakes

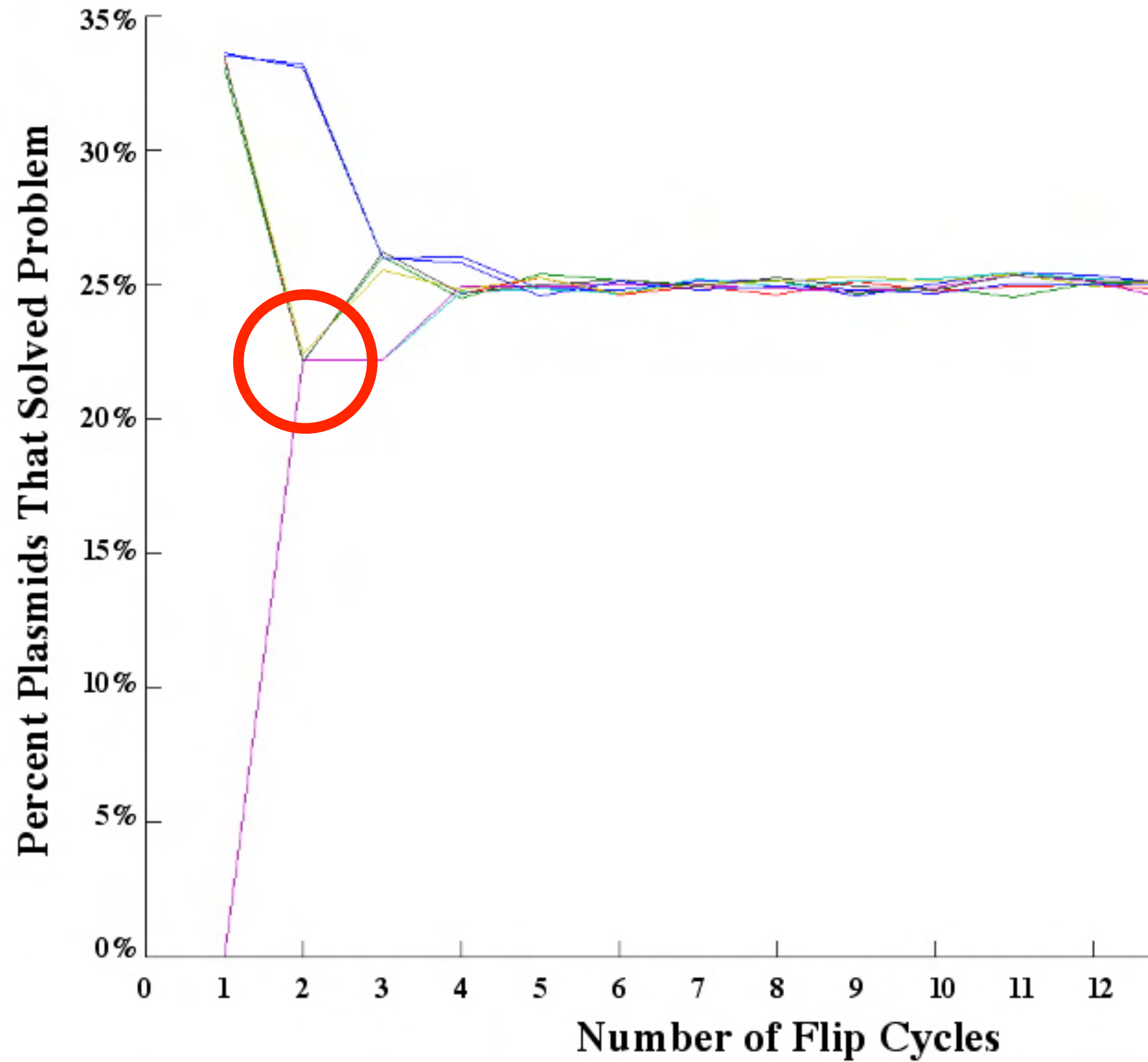
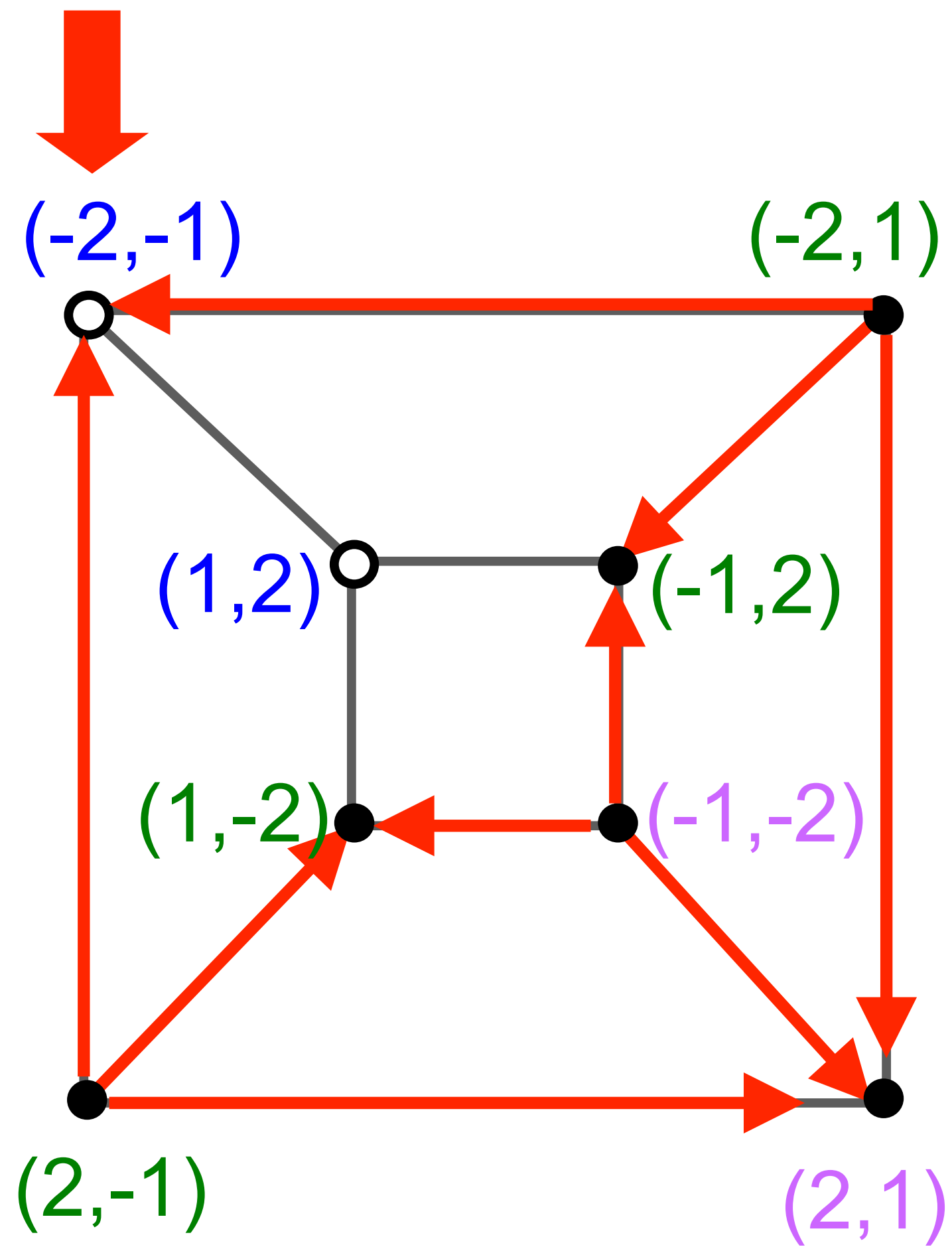

Modeling Burnt Pancakes

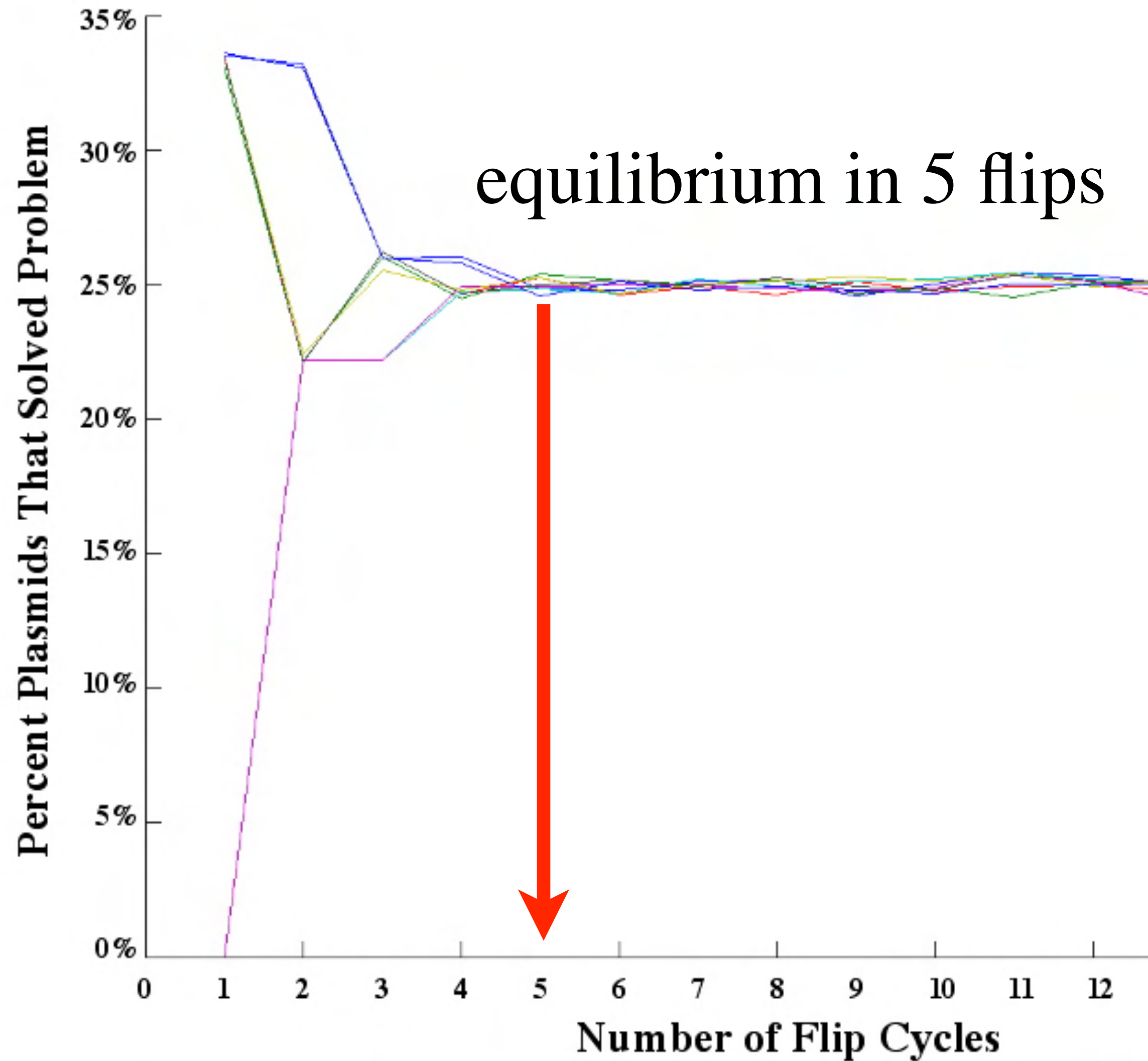
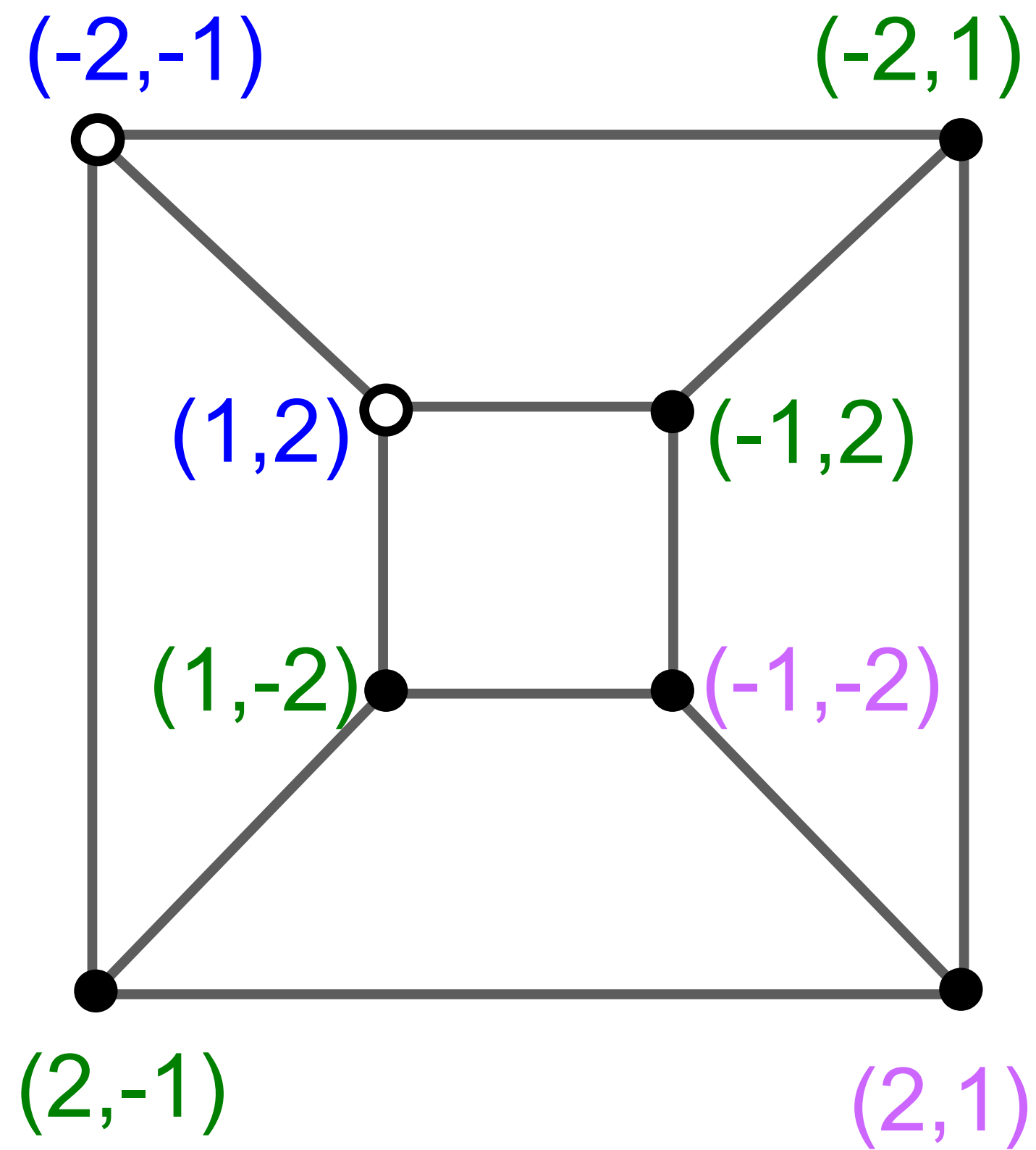



International Success



Outstanding Publication of 2008 in the *Journal of Biological Engineering*

On behalf of the editors of *Journal of Biological Engineering*, we recognize the contribution of the following authors for the most outstanding publication of the year.

“Engineering bacteria to solve the Burnt Pancake Problem”

Karmella A Haynes, Marian L Broderick, Adam D Brown, Trevor L Butner, James O Dickson, W Lance Harden, Lane H Heard, Eric L Jessen, Kelly J Malloy, Brad J Ogden, Sabriya Rosemond, Samantha Simpson, Erin Zwack, A Malcolm Campbell, Todd T Eckdahl, Laurie J Heyer, Jeffrey L Poet

Journal of Biological Engineering 2008, 2:8 (20 May 2008)



JOURNAL OF BIOLOGICAL
ENGINEERING

Mark R. Riley, 2006-2008 Editor-in-chief



- 2. Research** Open Access Highly accessed
Accesses **Engineering bacteria to solve the Burnt Pancake Problem**
21801 **Karmella A Haynes, Marian L Broderick, Adam D Brown, Trevor L Butner, James O Dickson, W
Lance Harden, Lane H Heard, Eric L Jessen, Kelly J Malloy, Brad J Ogden, Sabriya Rosemond,
Samantha Simpson, Erin Zwack, A Malcolm Campbell, Todd T Eckdahl, Laurie J Heyer, Jeffrey L
Poet**
Journal of Biological Engineering 2008, **2**:8 (20 May 2008)
[\[Abstract\]](#) [\[Full Text\]](#) [\[PDF\]](#) [\[PubMed\]](#) [\[Related articles\]](#)

12 undergraduate coauthors

Outstanding Publication of 2008 in the *Journal of Biological Engineering*

On behalf of the editors of *Journal of Biological Engineering*, we recognize the contribution of the following authors for the most outstanding publication of the year.

“Engineering bacteria to solve the Burnt Pancake Problem”

Karmella A Haynes, Marian L Broderick, Adam D Brown, Trevor L Butner, James O Dickson, W Lance Harden, Lane H Heard, Eric L Jessen, Kelly J Malloy, Brad J Ogden, Sabriya Rosemond, Samantha Simpson, Erin Zwack, A Malcolm Campbell, Todd T Eckdahl, Laurie J Heyer, Jeffrey L Poet

Journal of Biological Engineering 2008, 2:8 (20 May 2008)



JOURNAL OF BIOLOGICAL
ENGINEERING

Mark R. Riley, 2006-2008 Editor-in-chief



2.
Accesses
21801

Research **Open Access** **Highly accessed**

Engineering bacteria to solve the Burnt Pancake Problem

Karmella A Haynes, Marian L Broderick, Adam D Brown, Trevor L Butner, James O Dickson, W Lance Harden, Lane H Heard, Eric L Jessen, Kelly J Malloy, Brad J Ogden, Sabriya Rosemond, Samantha Simpson, Erin Zwack, A Malcolm Campbell, Todd T Eckdahl, Laurie J Heyer, Jeffrey L Poet

Journal of Biological Engineering 2008, **2**:8 (20 May 2008)

[\[Abstract\]](#) [\[Full Text\]](#) [\[PDF\]](#) [\[PubMed\]](#) [\[Related articles\]](#)

12 undergraduate coauthors

Can we solve the
SATisfiability problem?

Define the SATisfiability Problem



Define the SATisfiability Problem

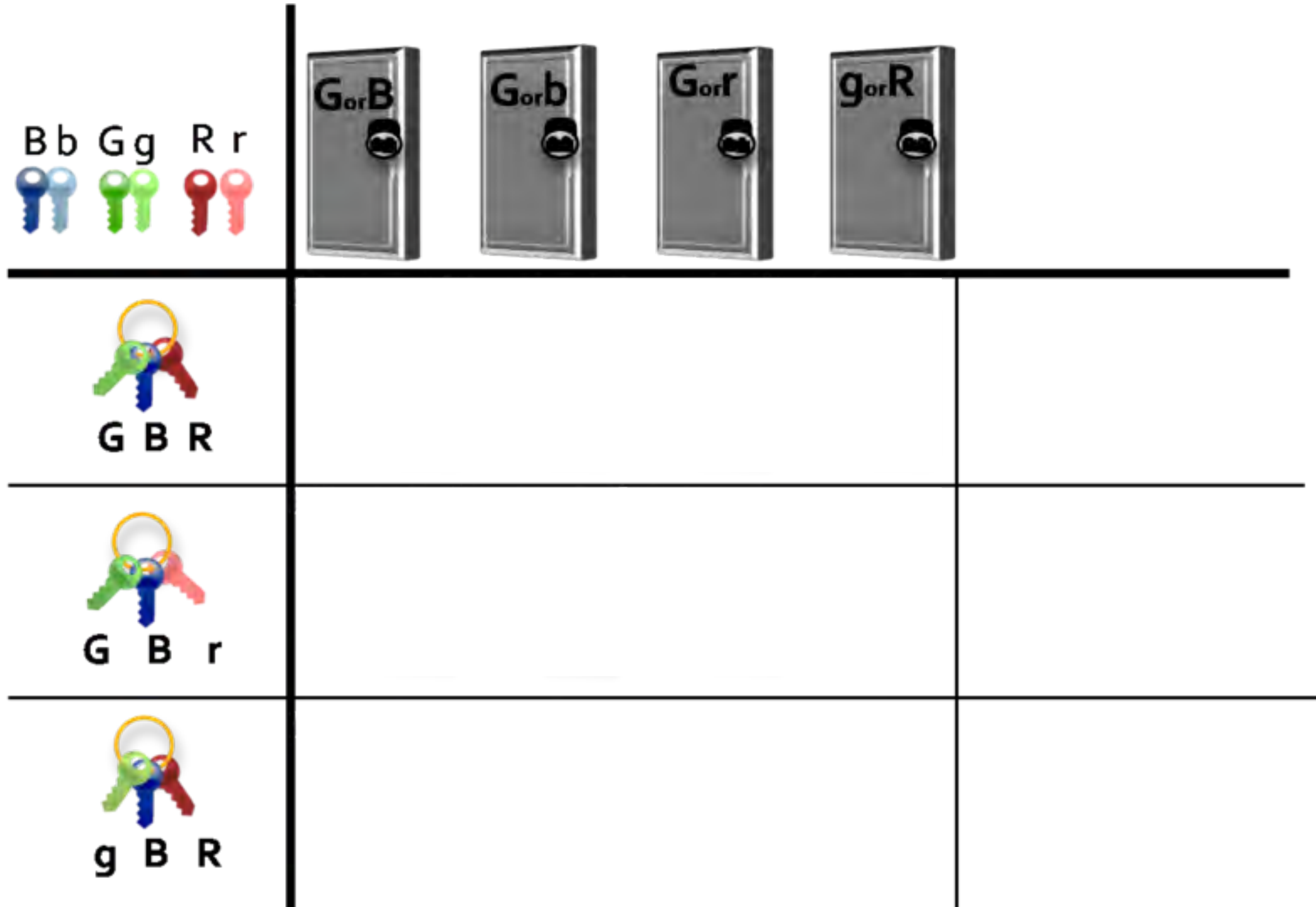

Define the SATisfiability Problem

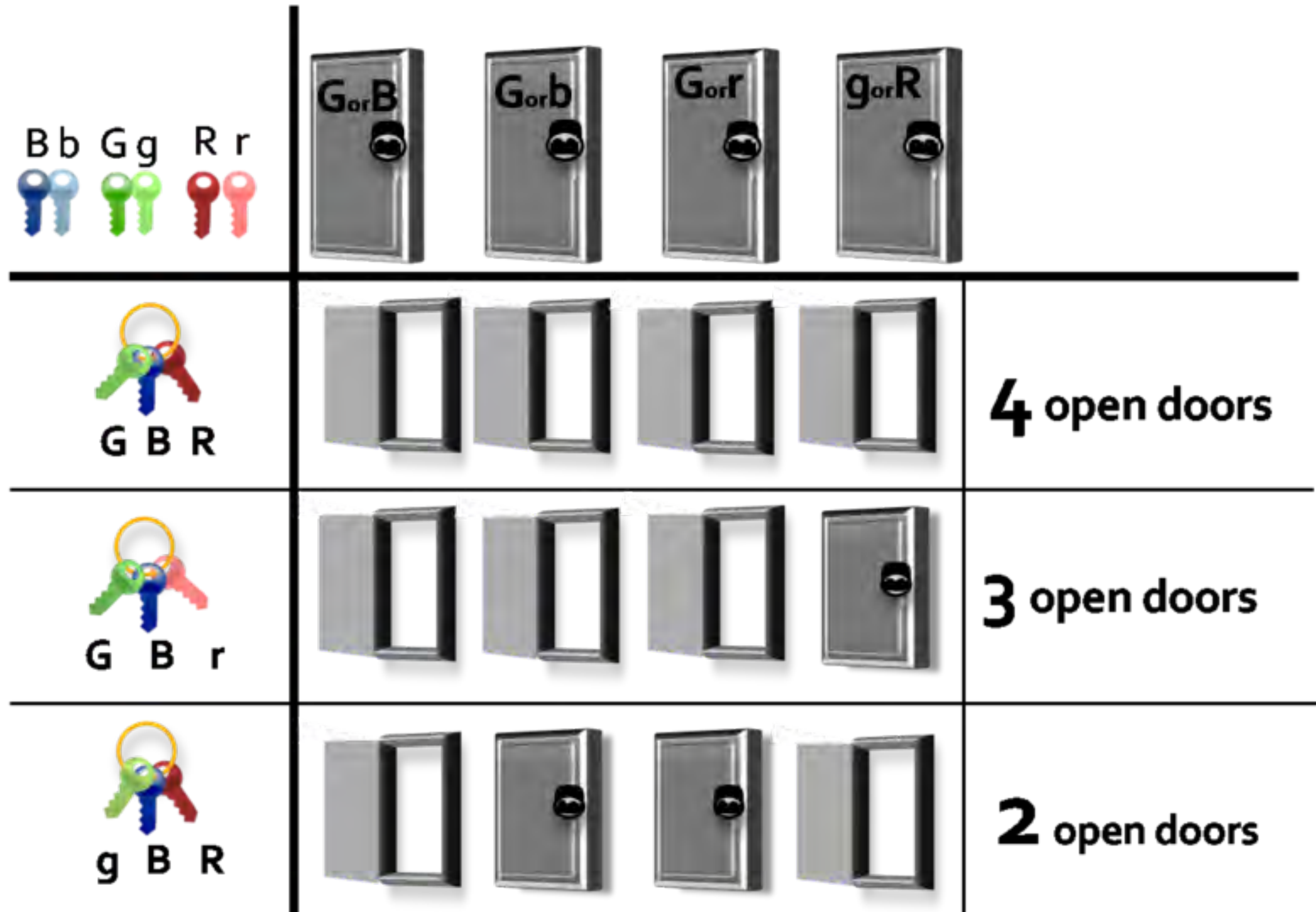

Converting Math to Biology

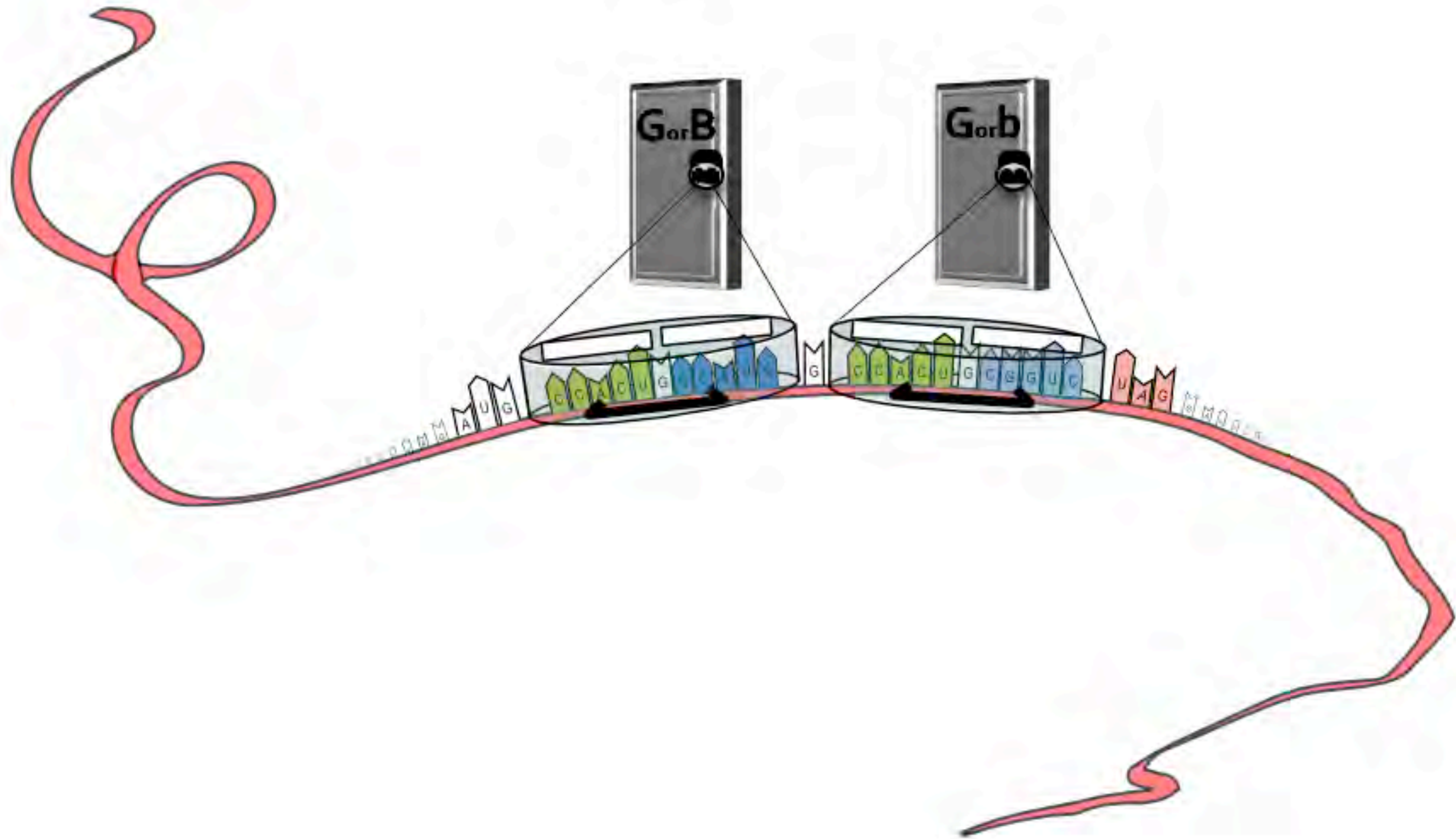

Central Dogma

DNA
atgccctactcactacctatagcgcat

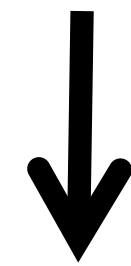

transcription

mRNA
aug ccc uac uca cua ccu aua ccg cau

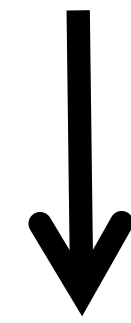

translation

Protein
M P Y S H P I P H

Frameshift Mutation

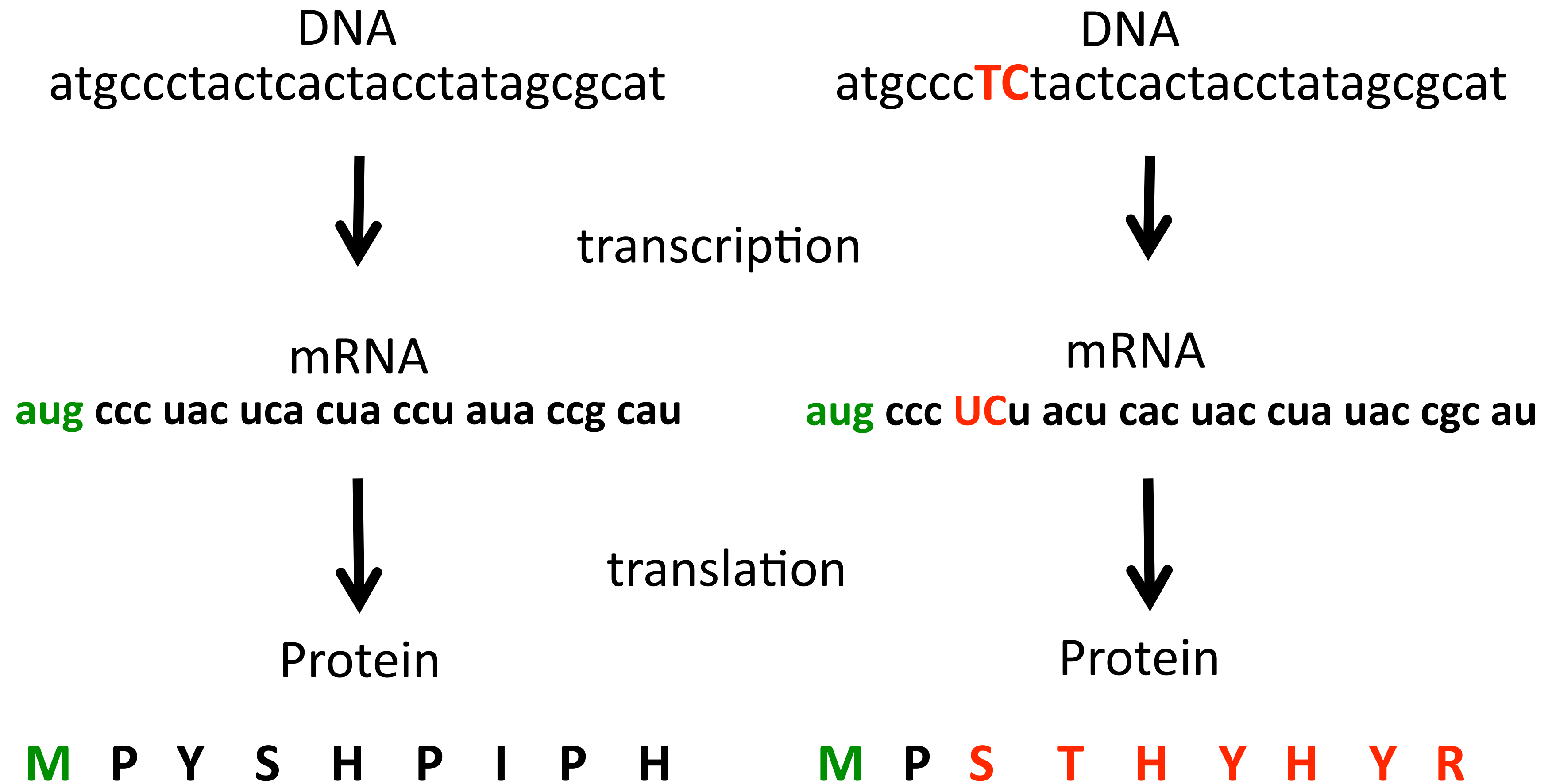

Frameshift Suppression

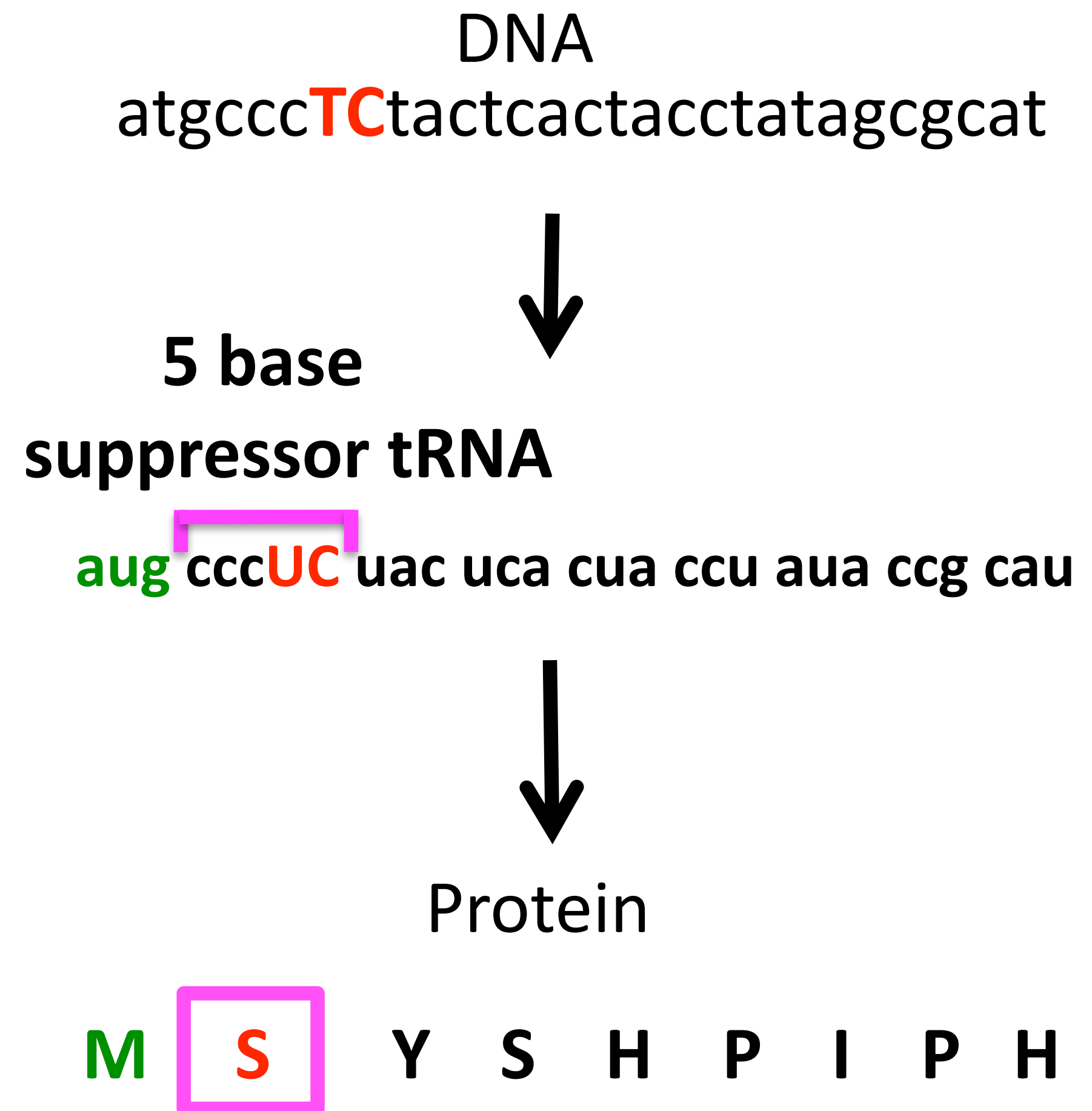
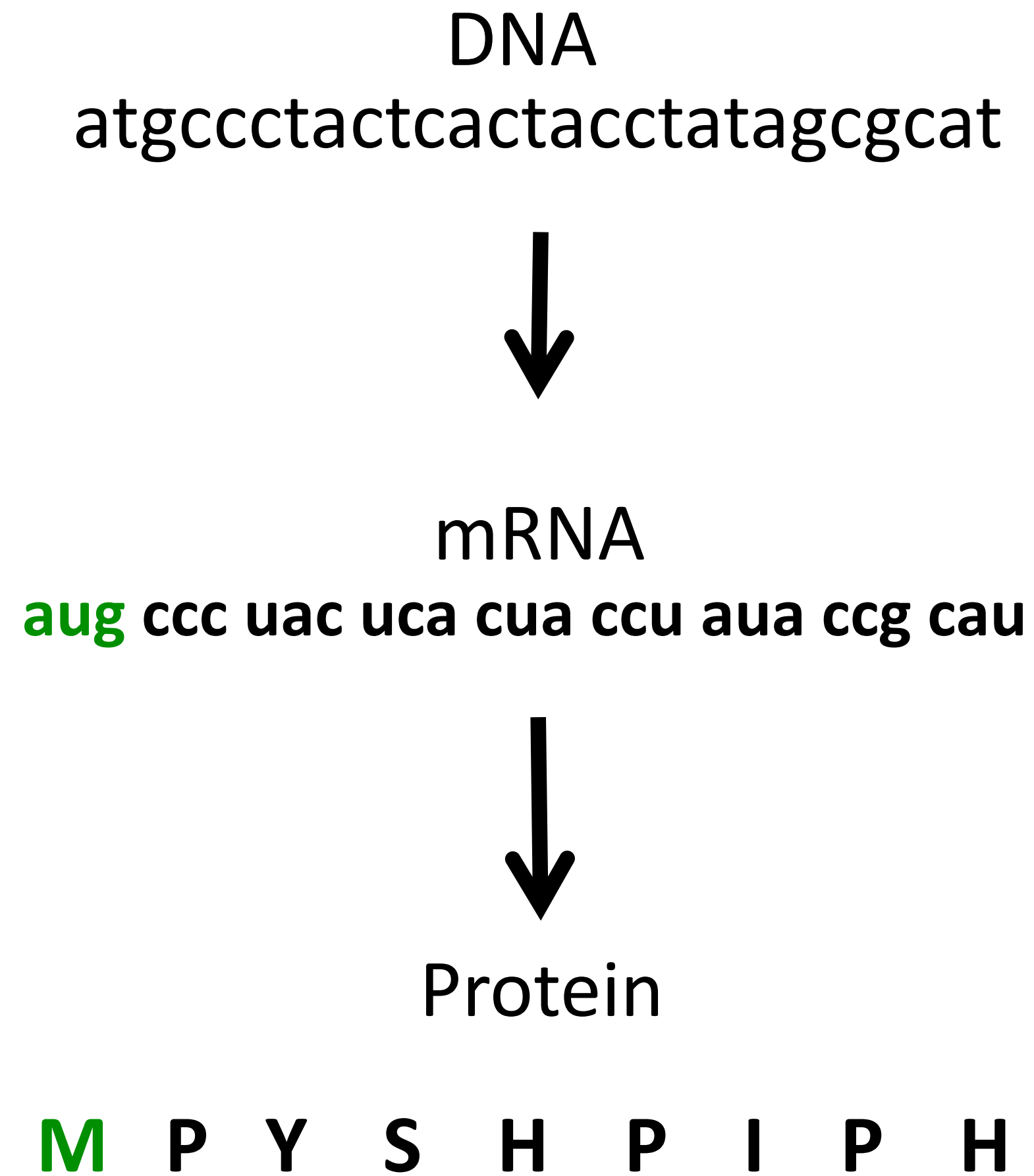

Suppressor tRNA

core tRNA
nucleotides

serine

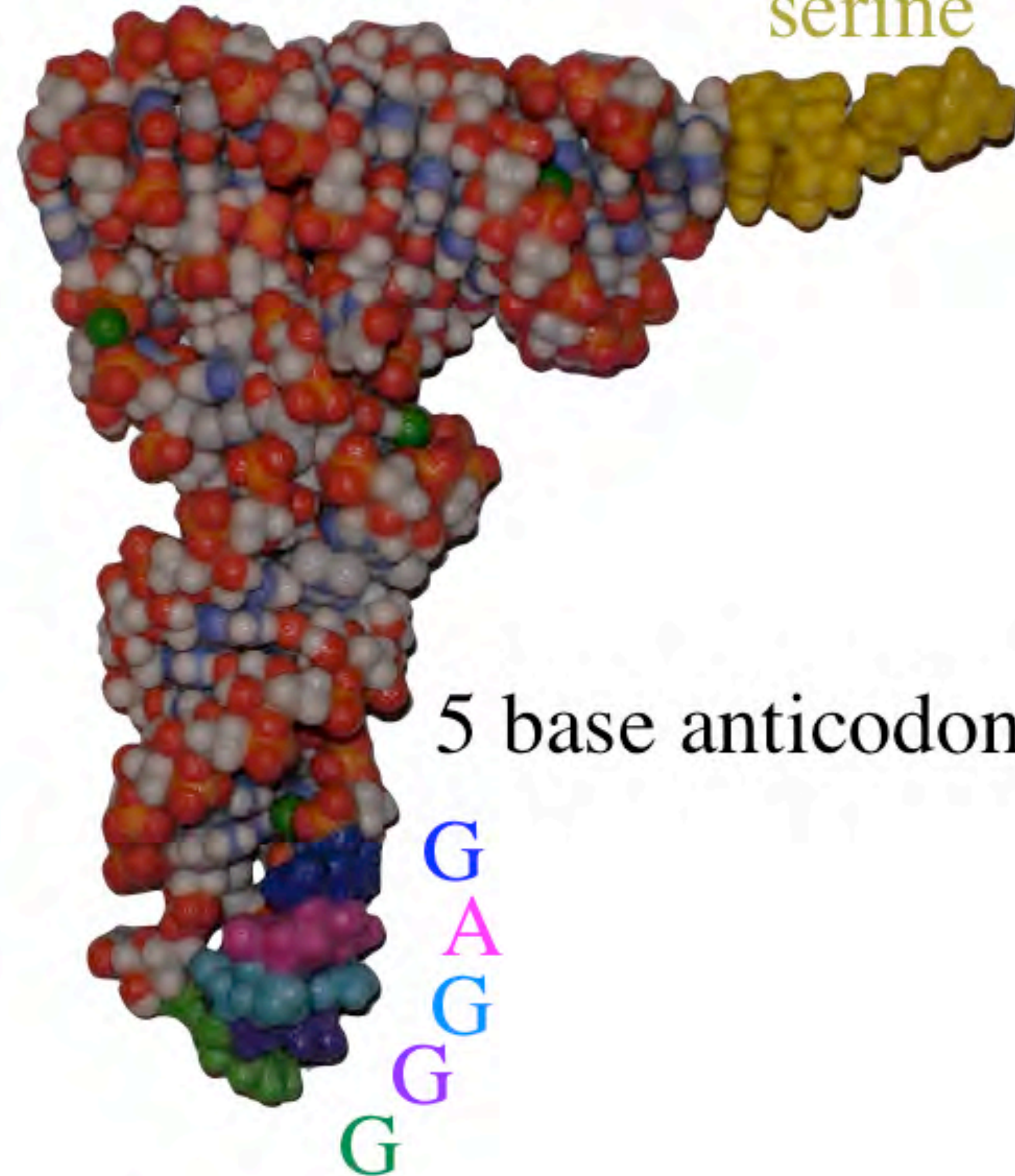

Coding 2-SAT Clause

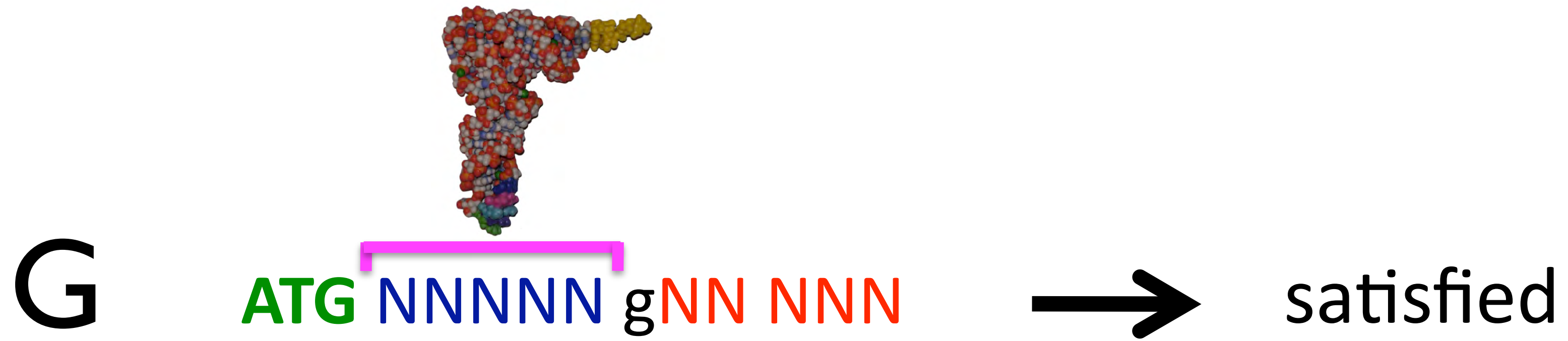

Coding 2-SAT Clause

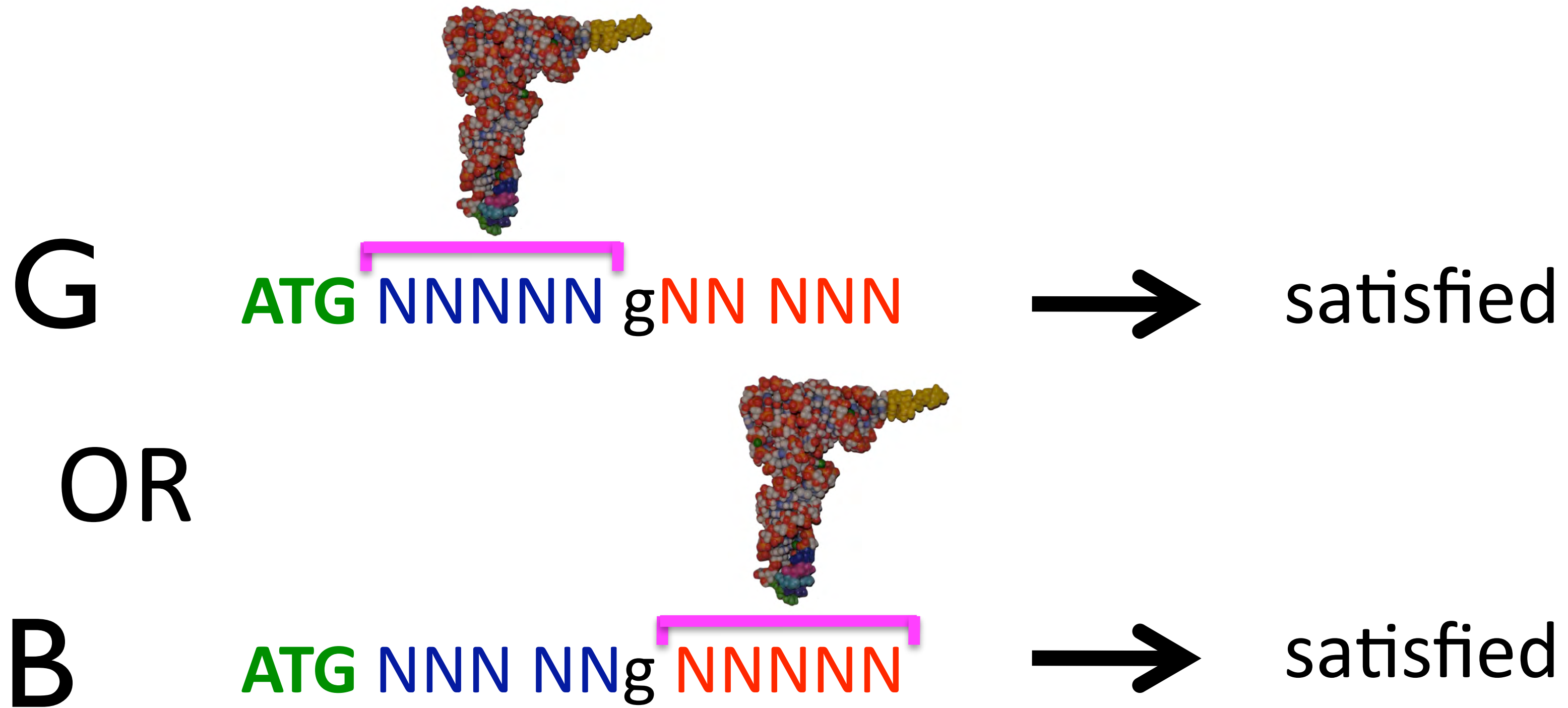

Coding 2-SAT Clause

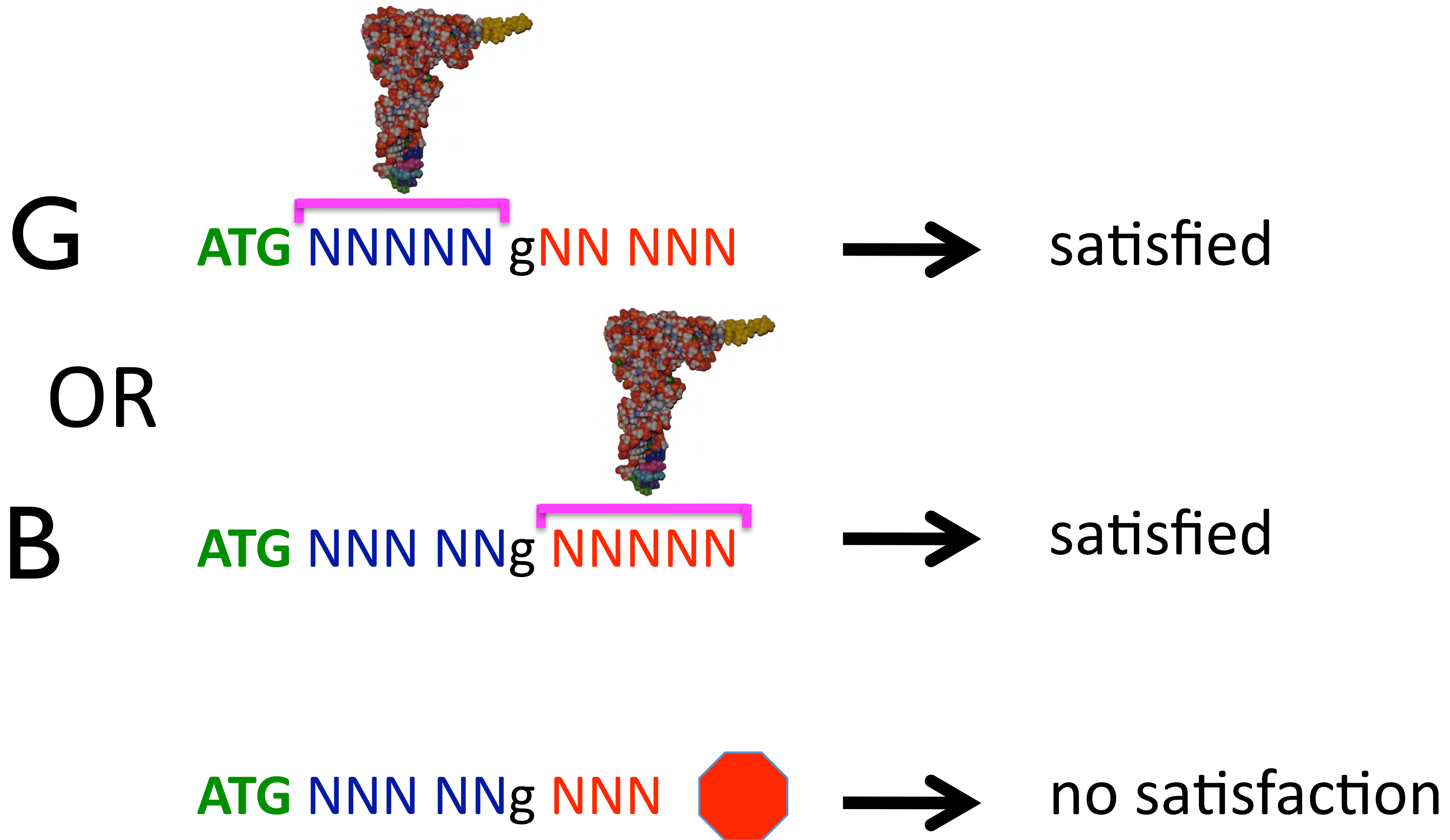

Redesign System v2.0

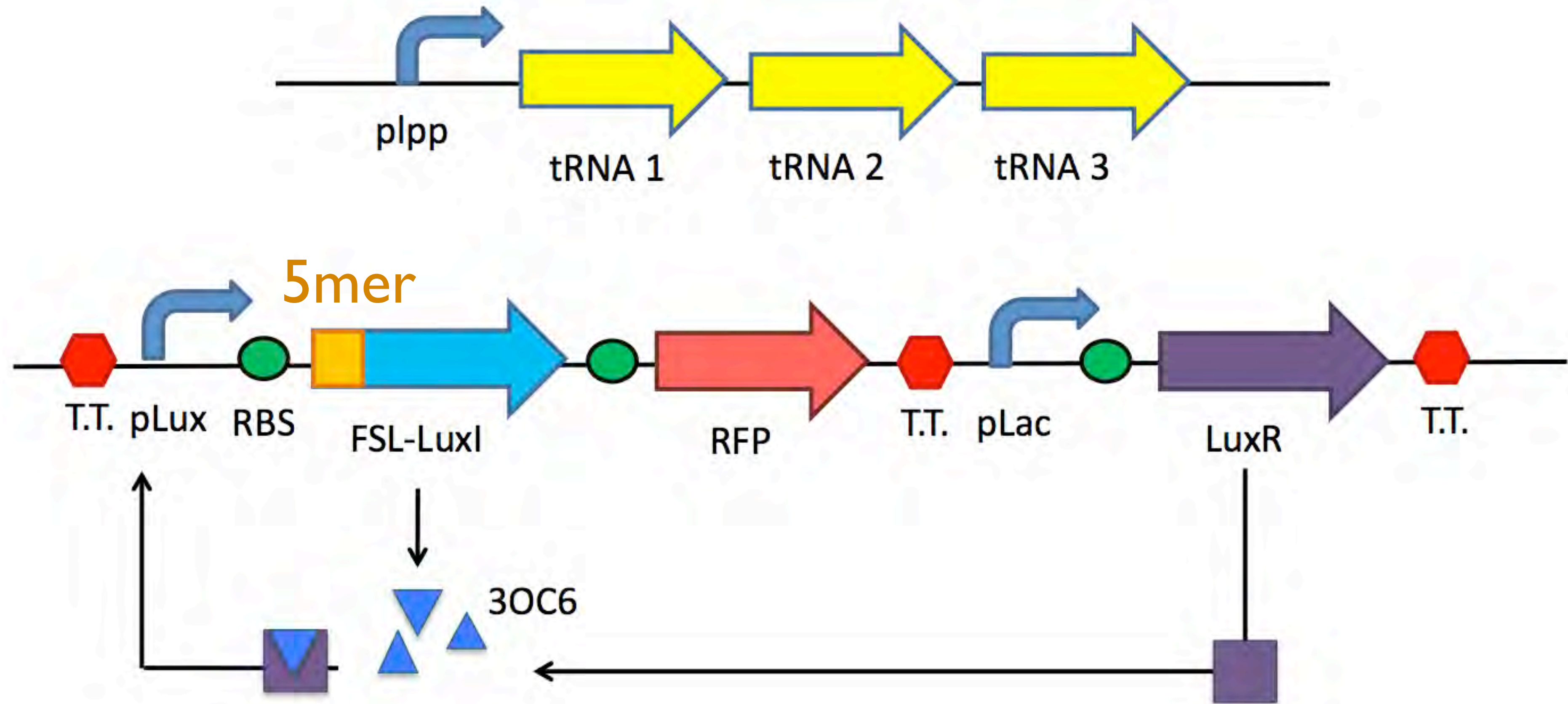

Outcomes of v 2.0

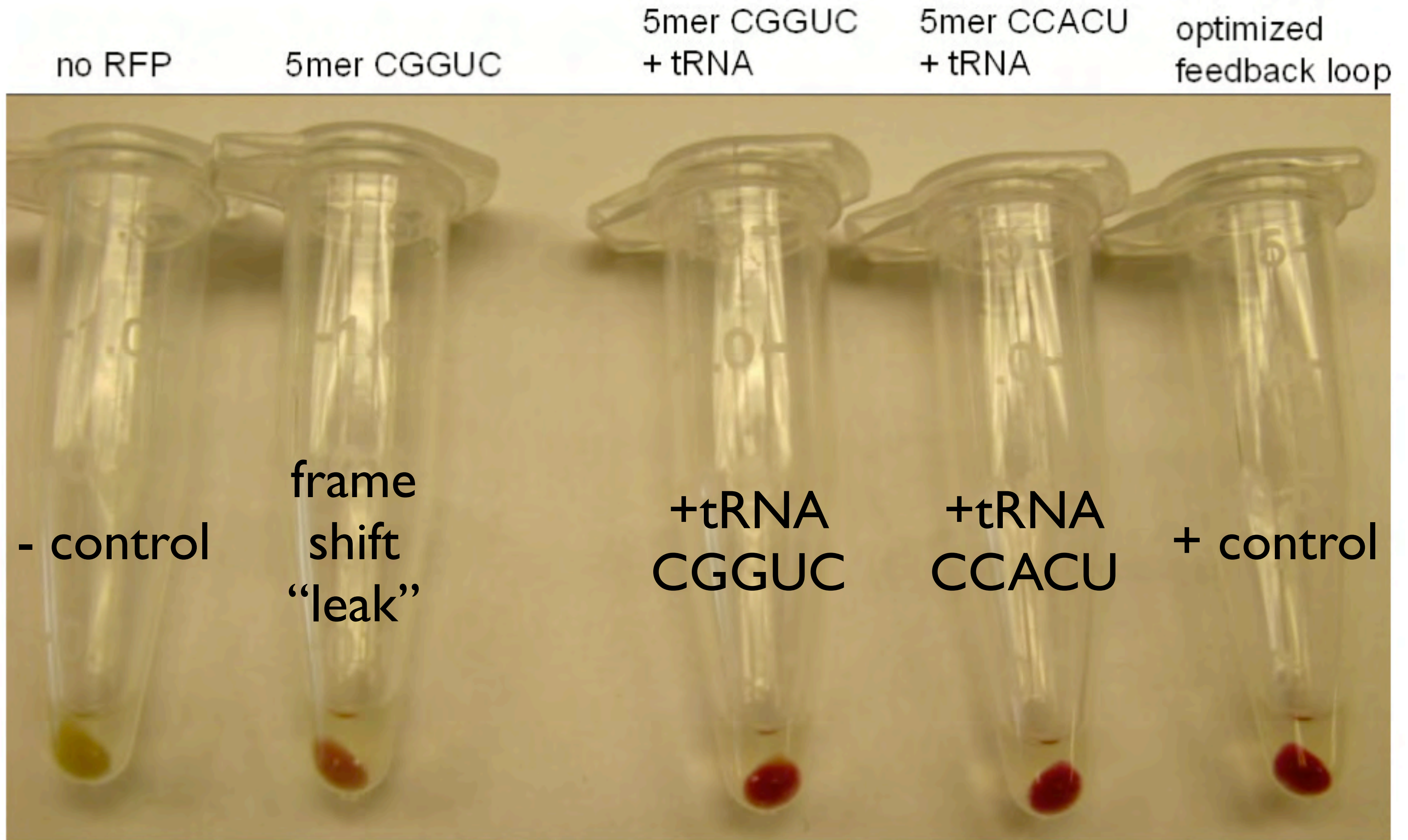

Outcomes of v 2.0

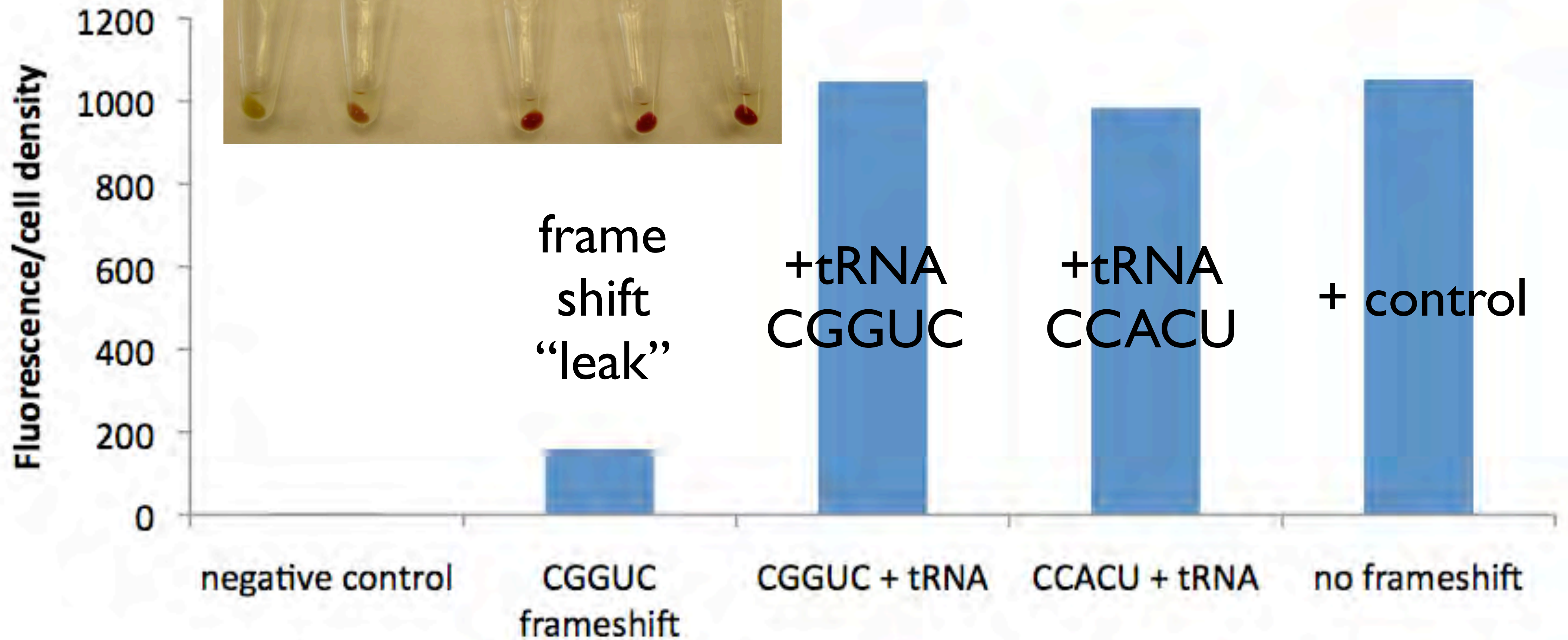
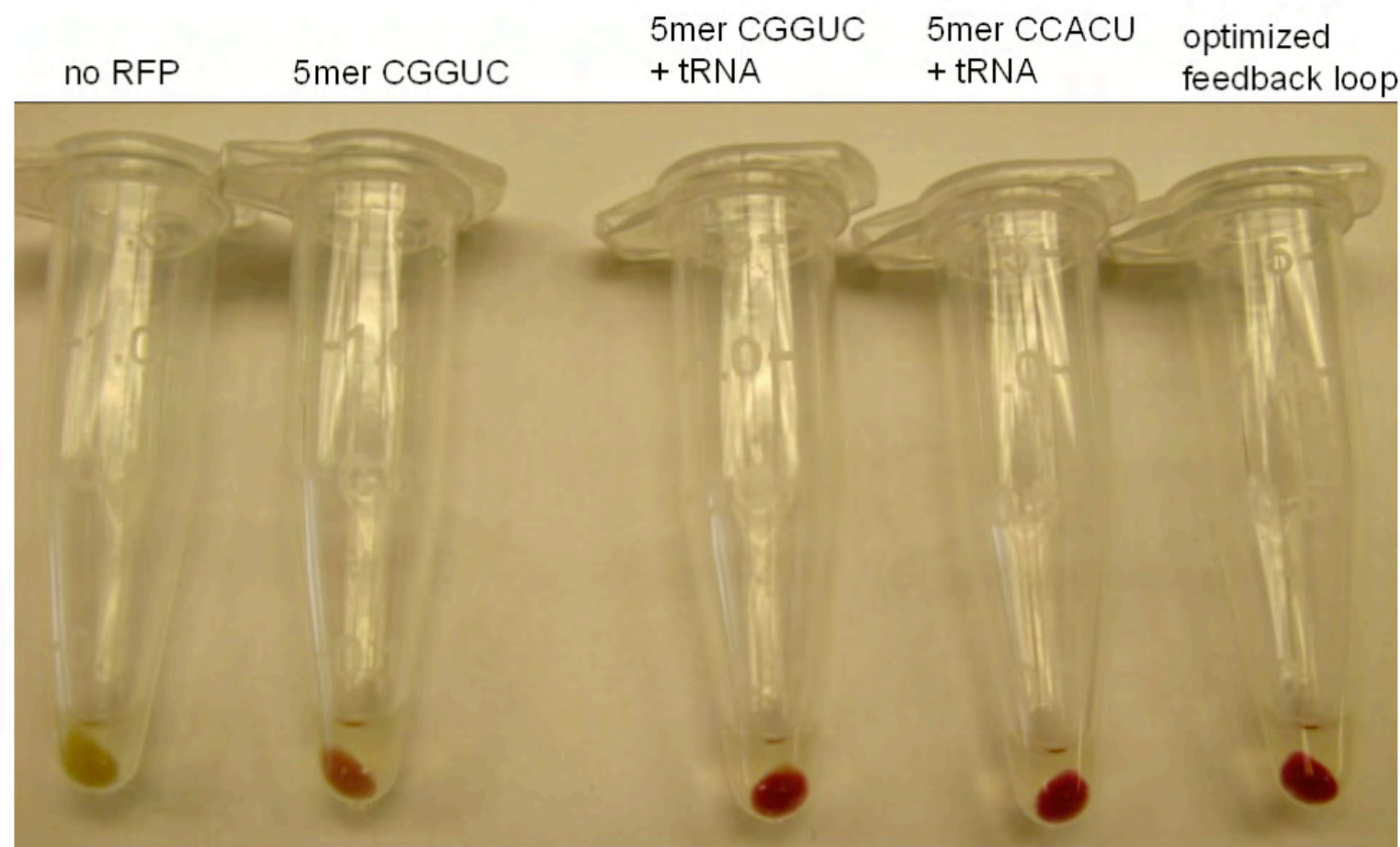

Why build bacterial computers?

Evolution of Computers

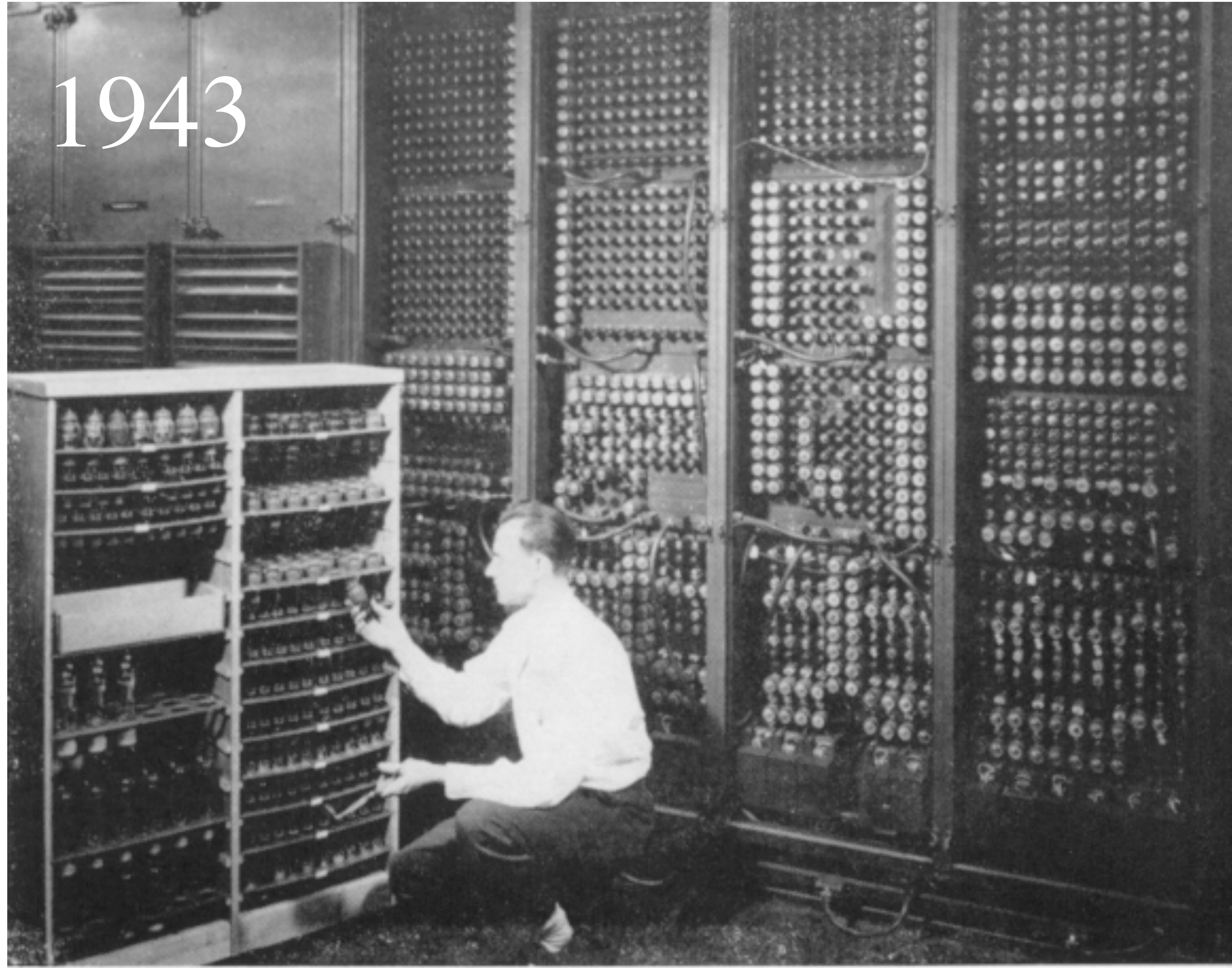

Evolution of Computers

iPhone in 2011

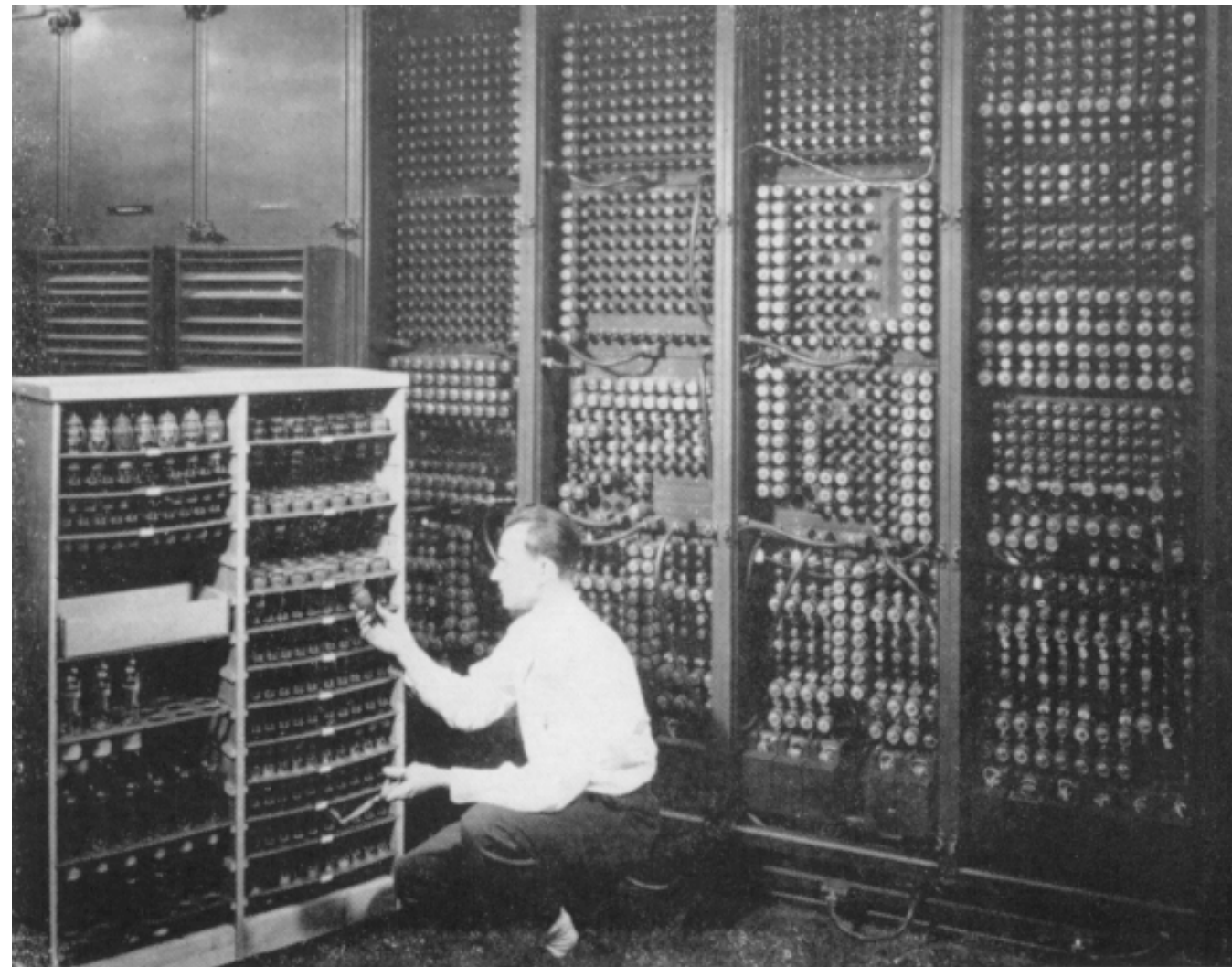

Evolution of Bacterial Computers

E. coli in 2011

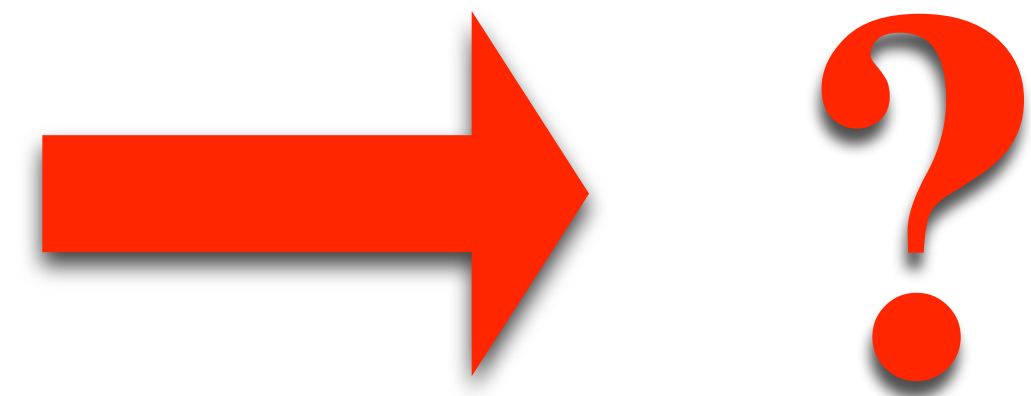
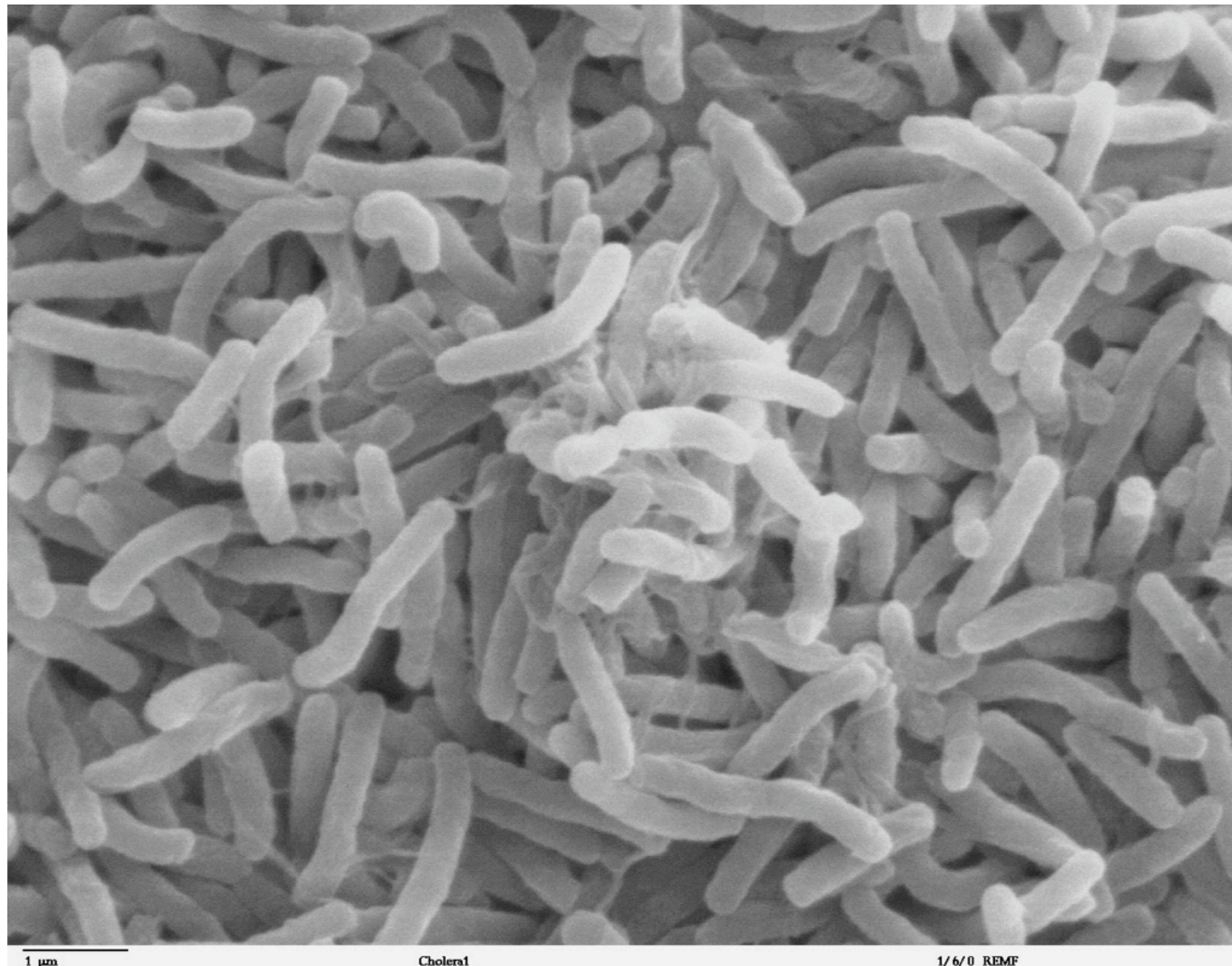

Living Hardware
in 2021

Increased Student Diversity

56 undergraduates in 7 years

African American	Hispanic	First Generation	Asian Minority	Asian Majority
14	2	9	2	7

PhD	Dual degree	MD	MPH	Jobs		at DC
13	2	2	3	5	7	27

campus: 74% Caucasian

biology majors: 87% Caucasian

G**C**A**T** Faculty Workshop

Synthetic Biology

20 pairs of faculty
1 Bio + 1 Other
pending at NSF

TEACHING IS IN MY GENES

Thr Glu Ala Cys His Ile Asn Gly Ile Ser Ile Asn Met Tyr Gly Glu Asn Glu Ser

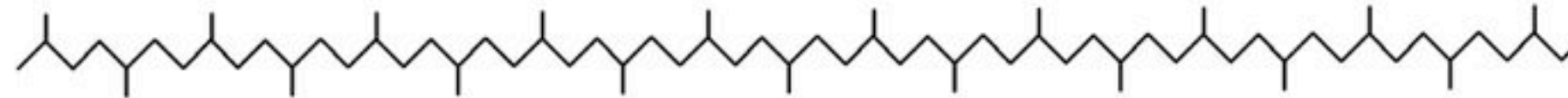

ACU GAA GCU UGU CAU AUU AAU GGU AUU UCU AUU AAU AUG UAU GGU GAA AAU GAA UCU



TGA CTT CGA ACA GTA TAA TTA CCA TAA AGA TAA TTA TAC ATA CCA CTT TTA CTT AGA
ACT GAA GCT TGT CAT ATT AAT GGT ATT TCT ATT AAT ATG TAT GGT GAA AAT GAA TCT

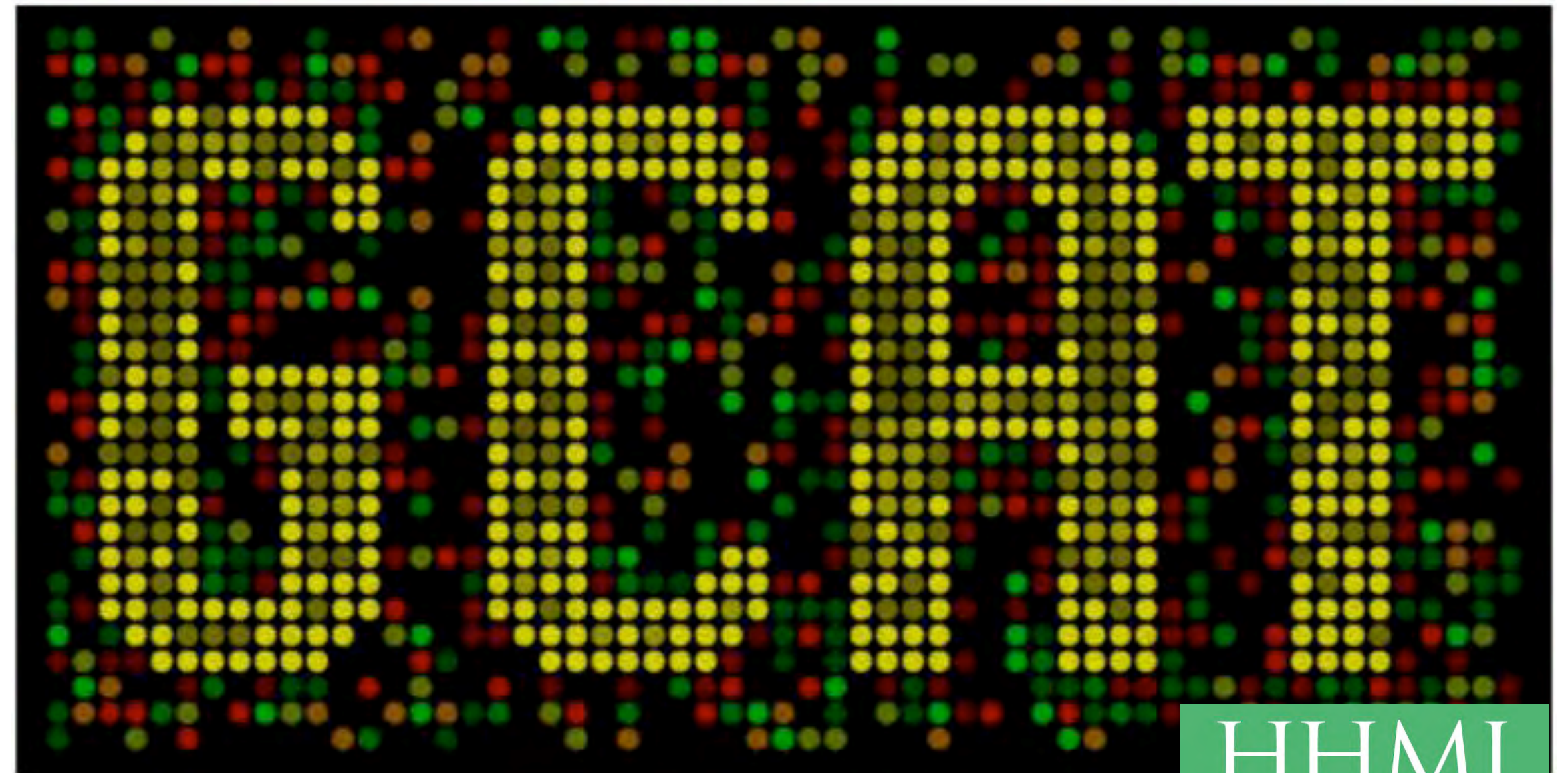

HHMI
HOWARD HUGHES
MEDICAL INSTITUTE

**Our Current Challenge:
Introductory Biology**

Integrating Concepts in Biology

by

A. Malcolm Campbell, Laurie J. Heyer
and Christopher J. Paradise

What's Wrong with Biology Education Now?

- Vocabulary is emphasized
- Experimental approaches are minimized
- Math is absent
- Memorization is rewarded
- Critical thinking is discouraged
- Information is irrelevant to students

If we currently cover all the important stuff....



...how can we add more content?

Too much content for the containers



Start with the literature...

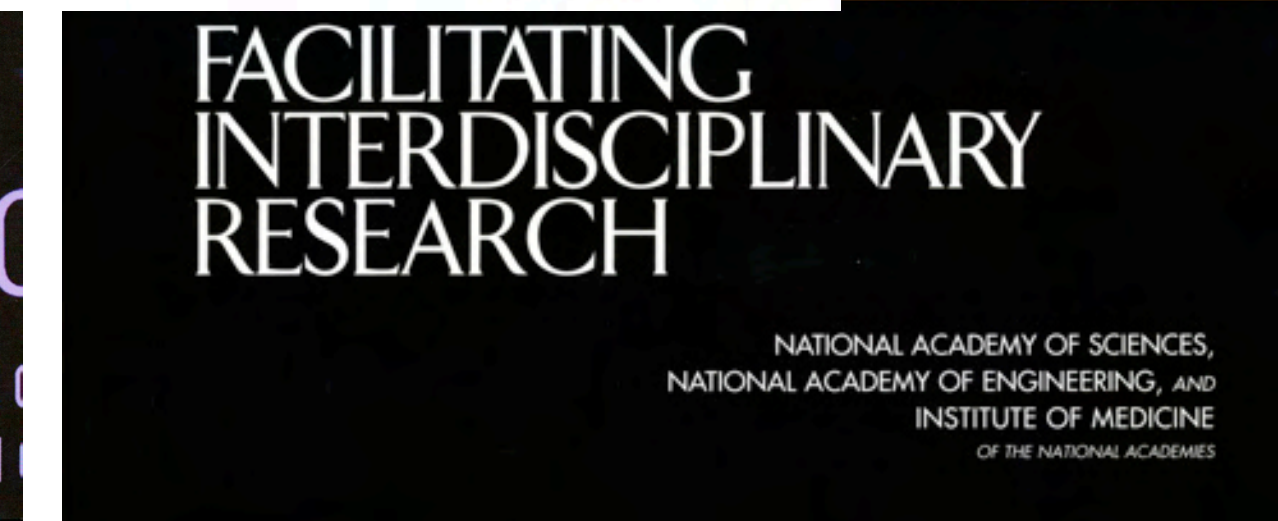
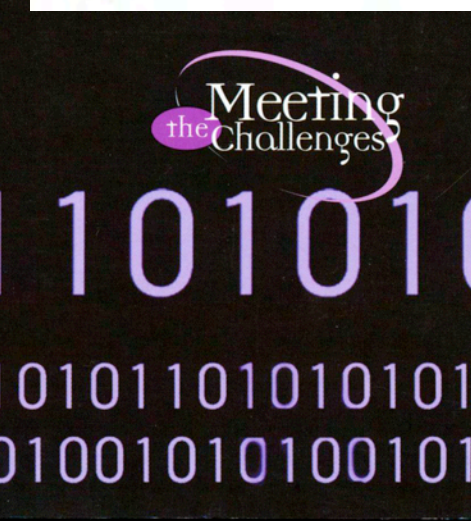
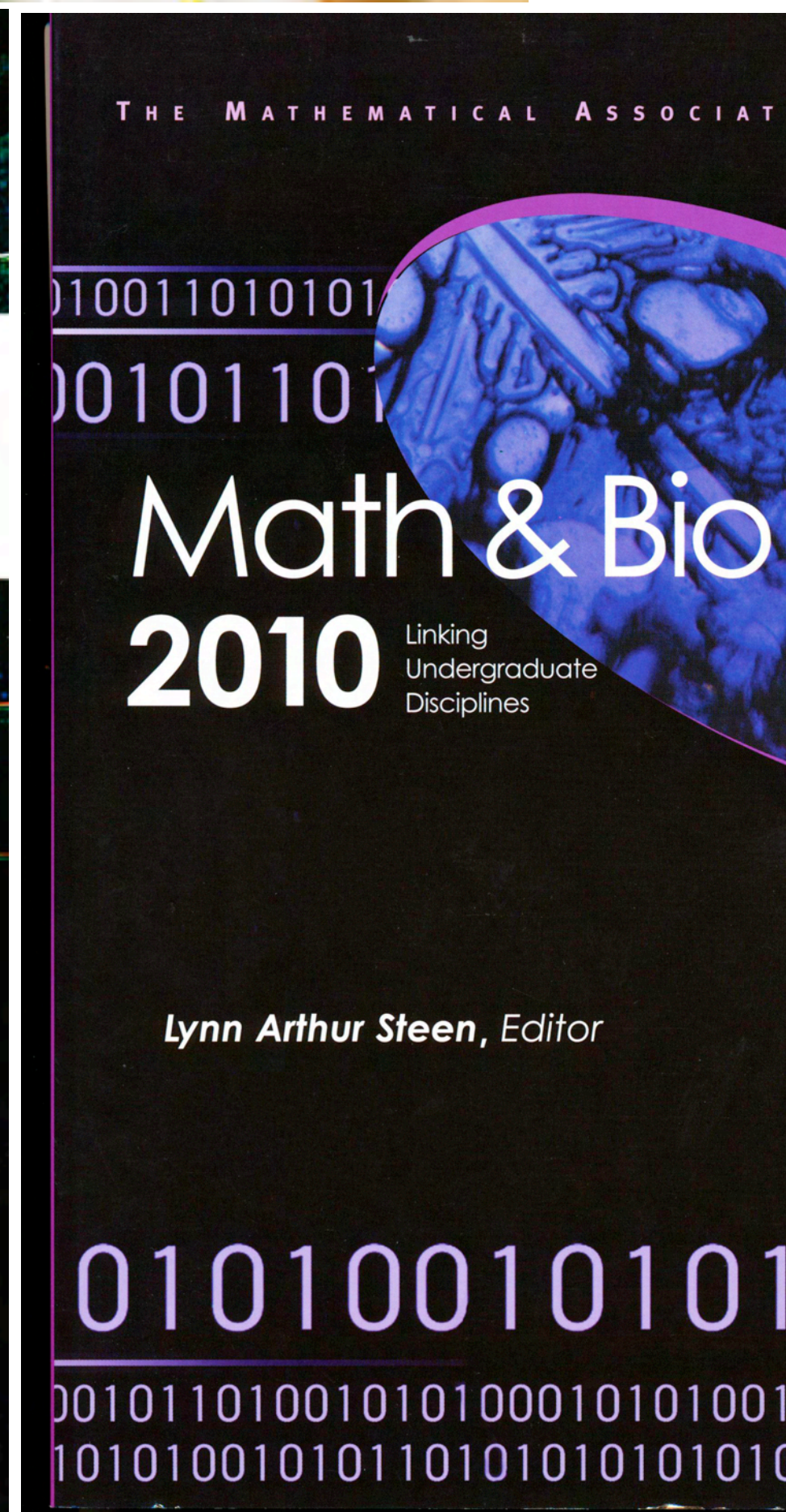
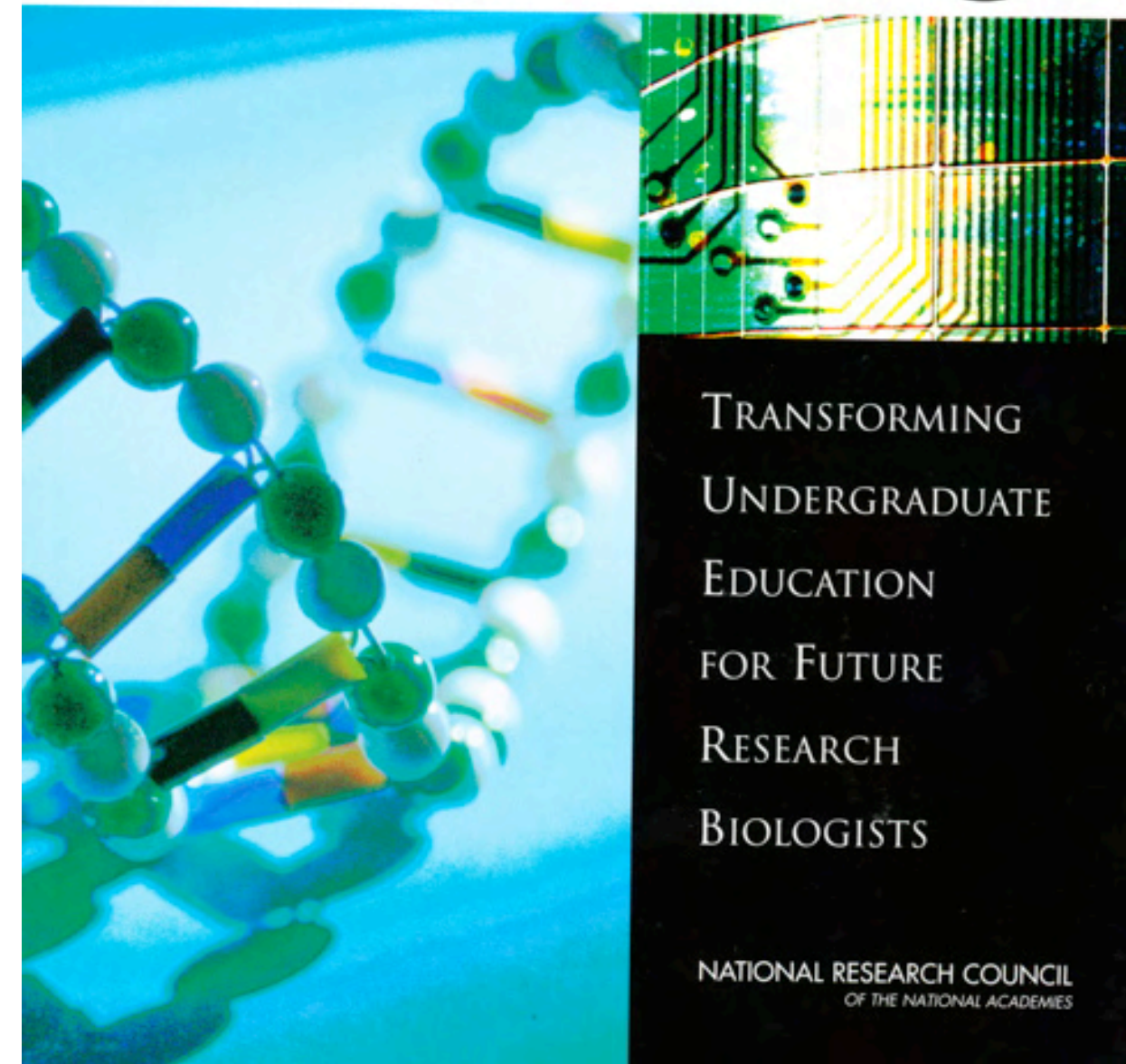
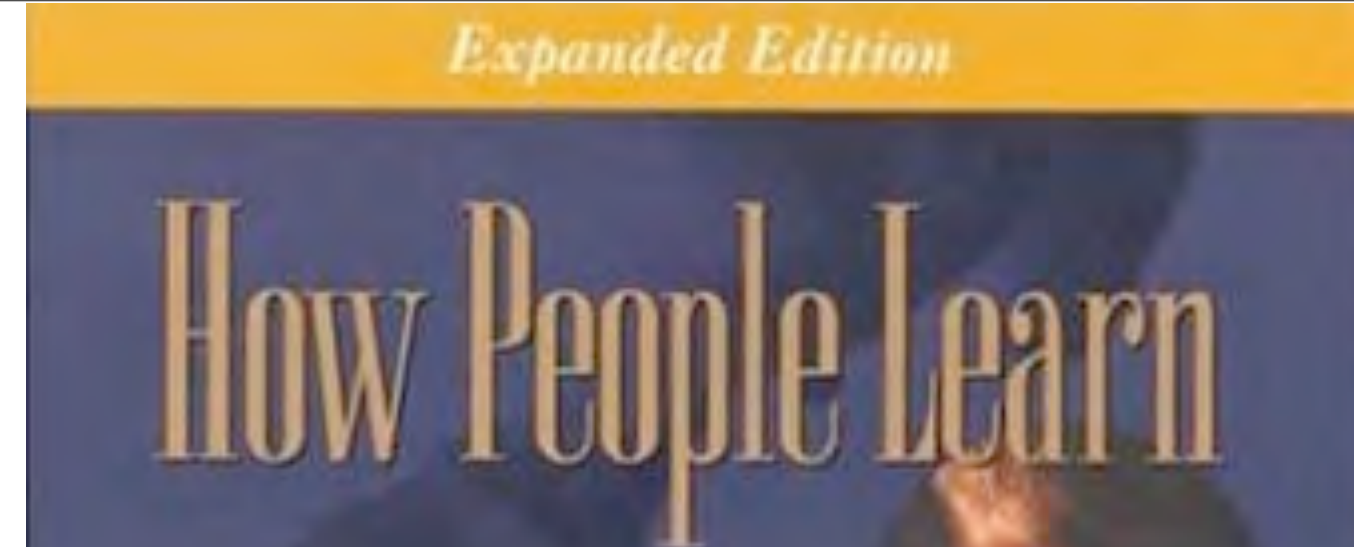

Present information and data...



... in the context of the big picture.



Artificial Divide within Biology

Small Biology

Big Biology

Five Levels of Organization

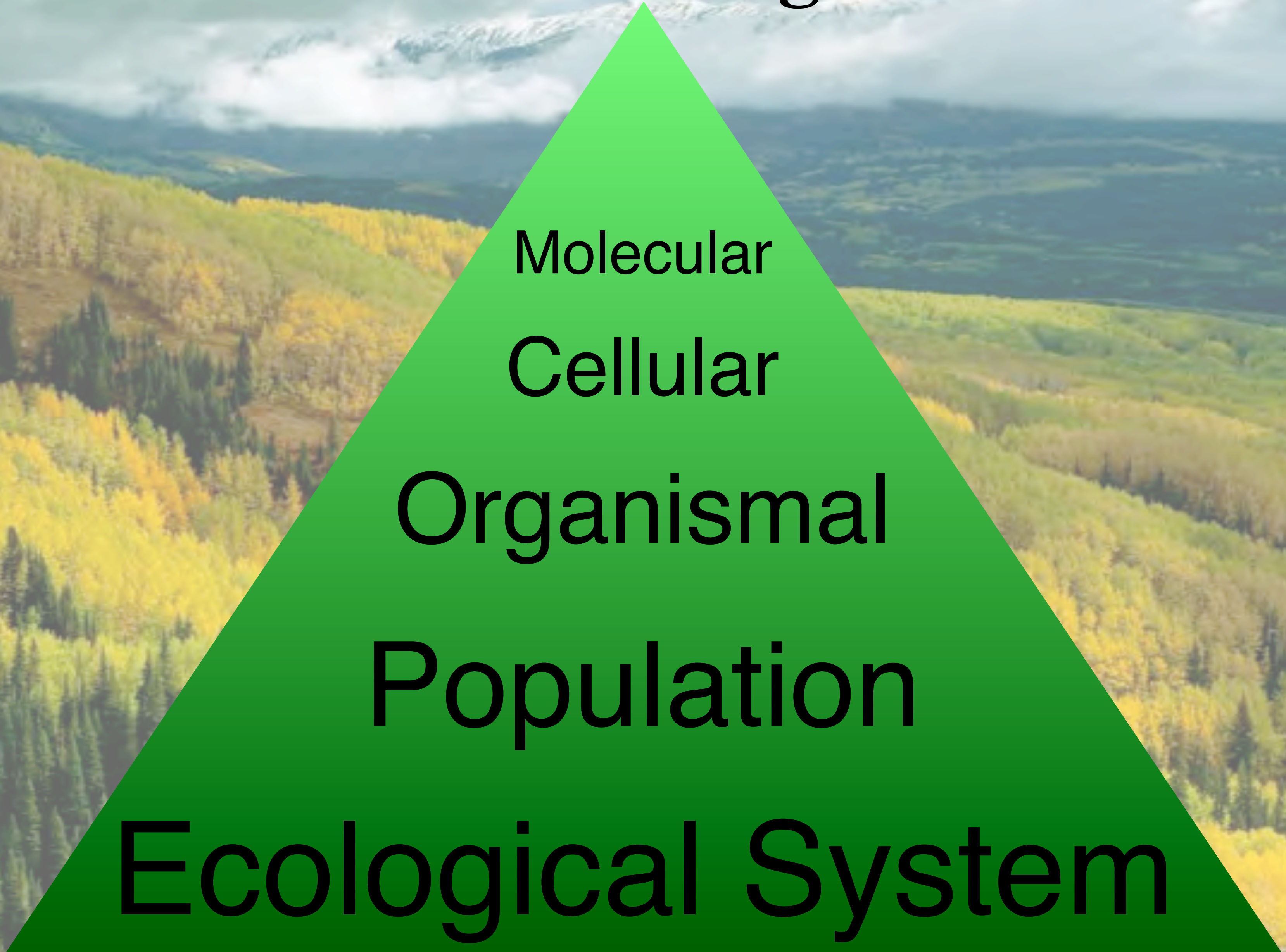

Molecular
Cellular
Organismal
Population
Ecological System

Five Big Ideas of Biology

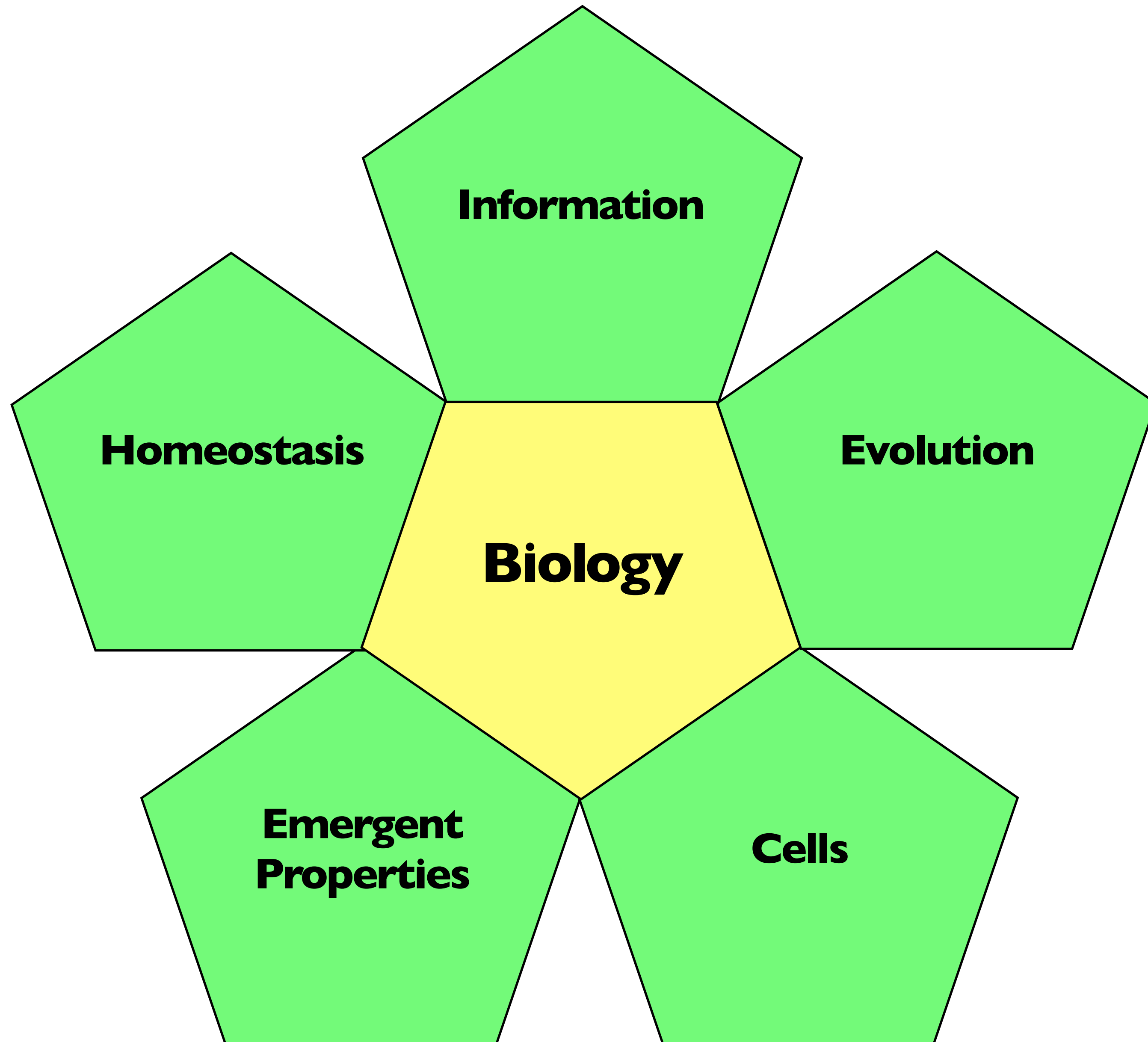

Five by Five Matrix of Biology

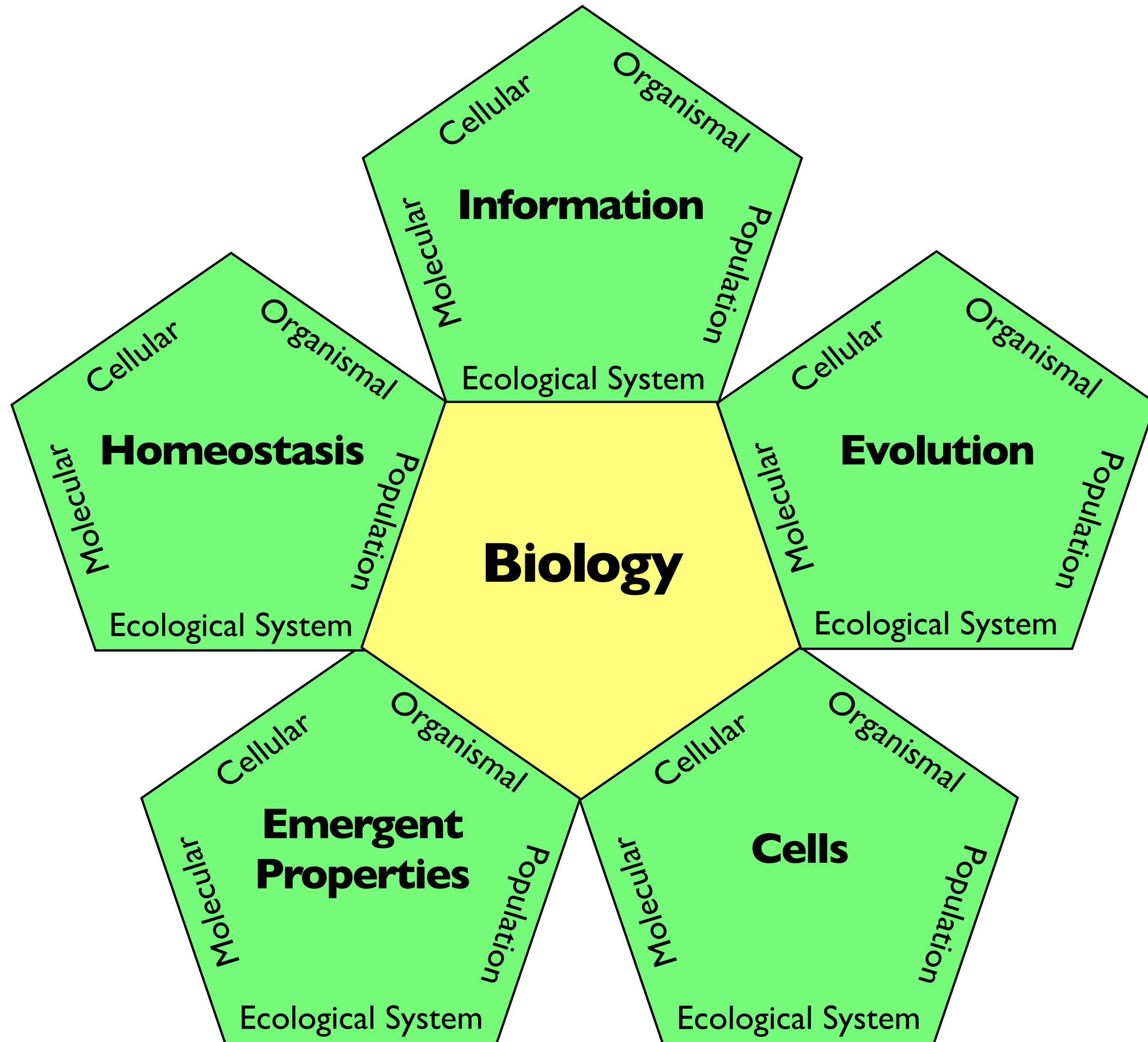

Five by Five Matrix of Biology

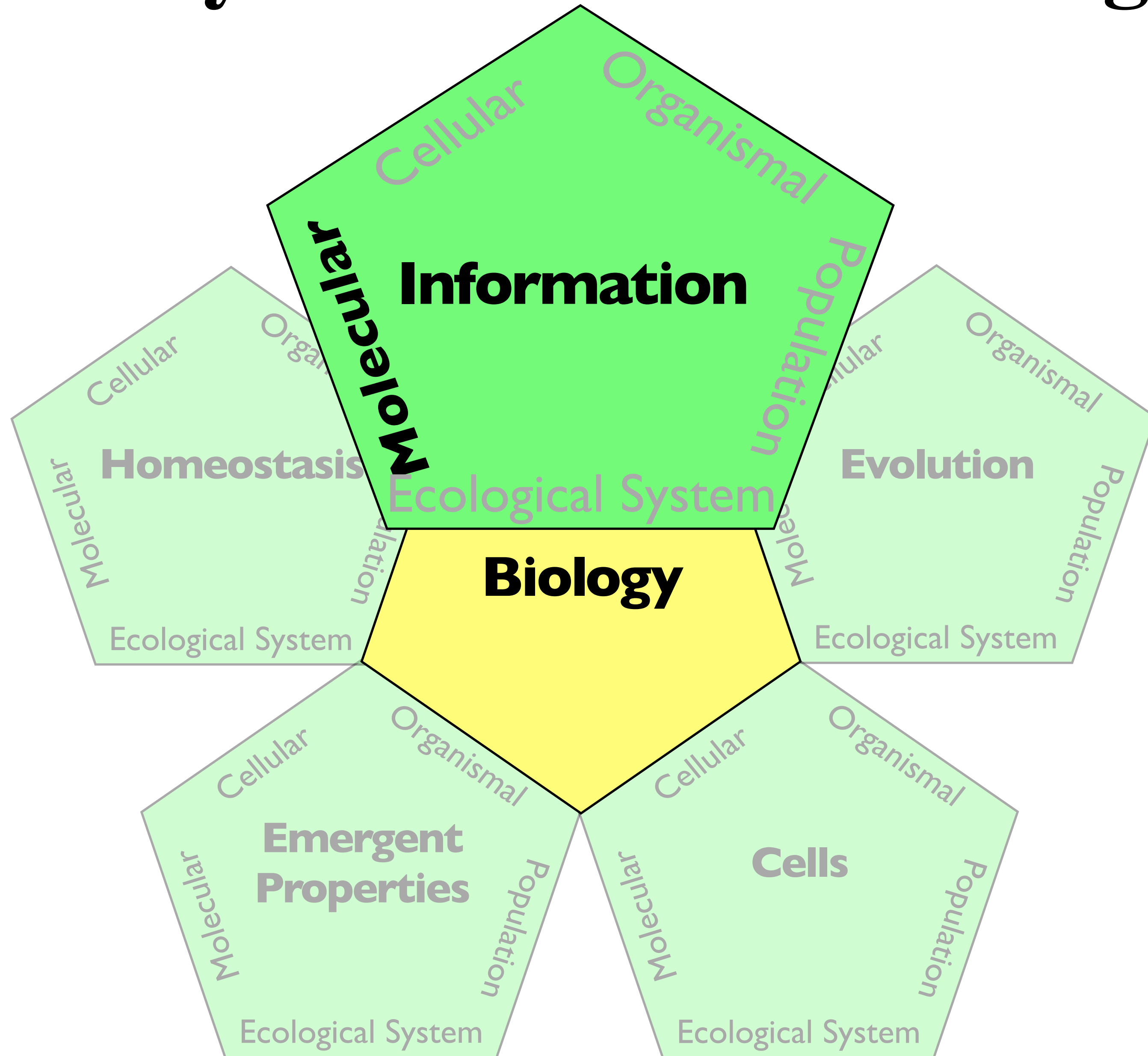

Five by Five Matrix of Biology

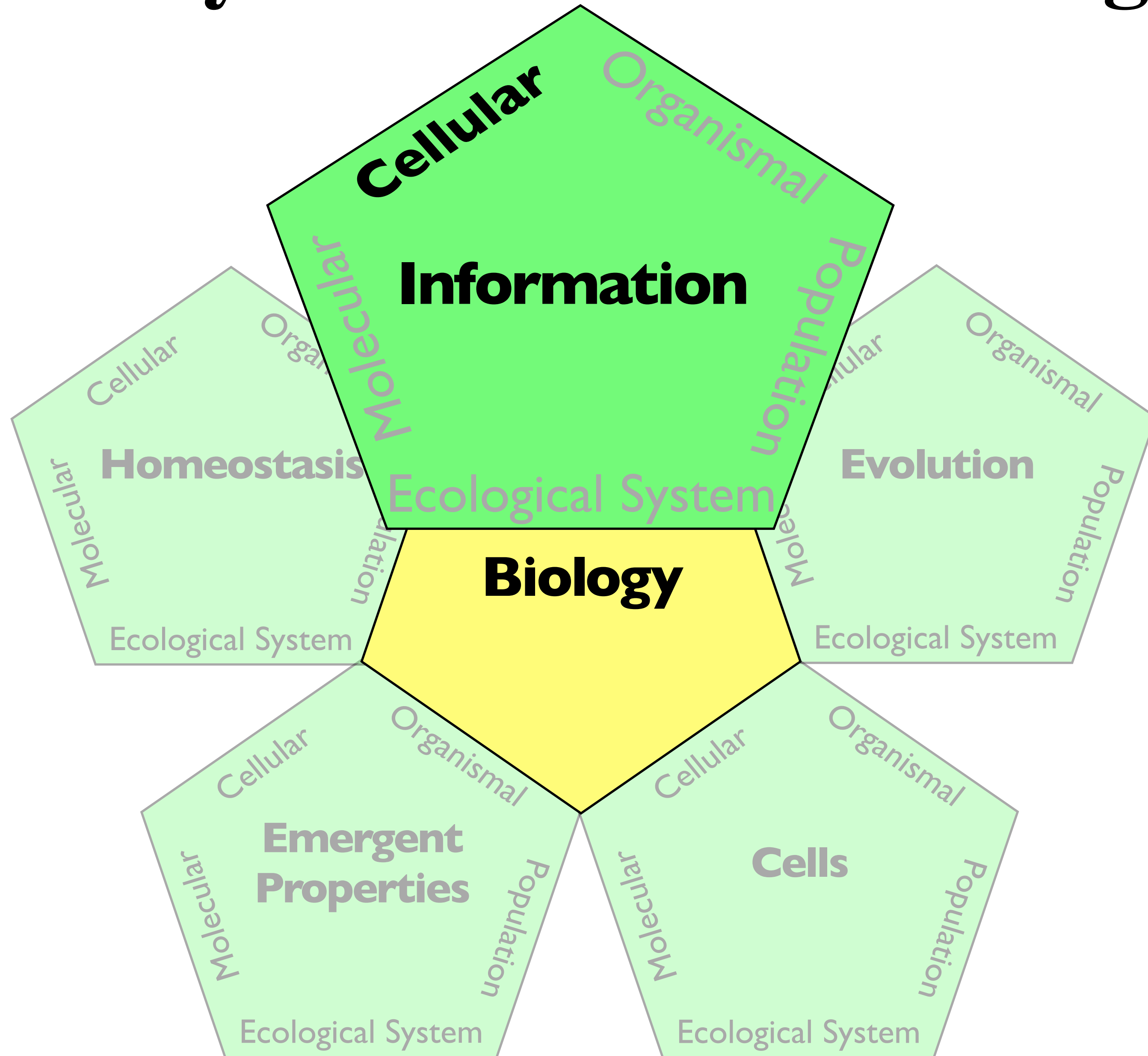

Five by Five Matrix of Biology

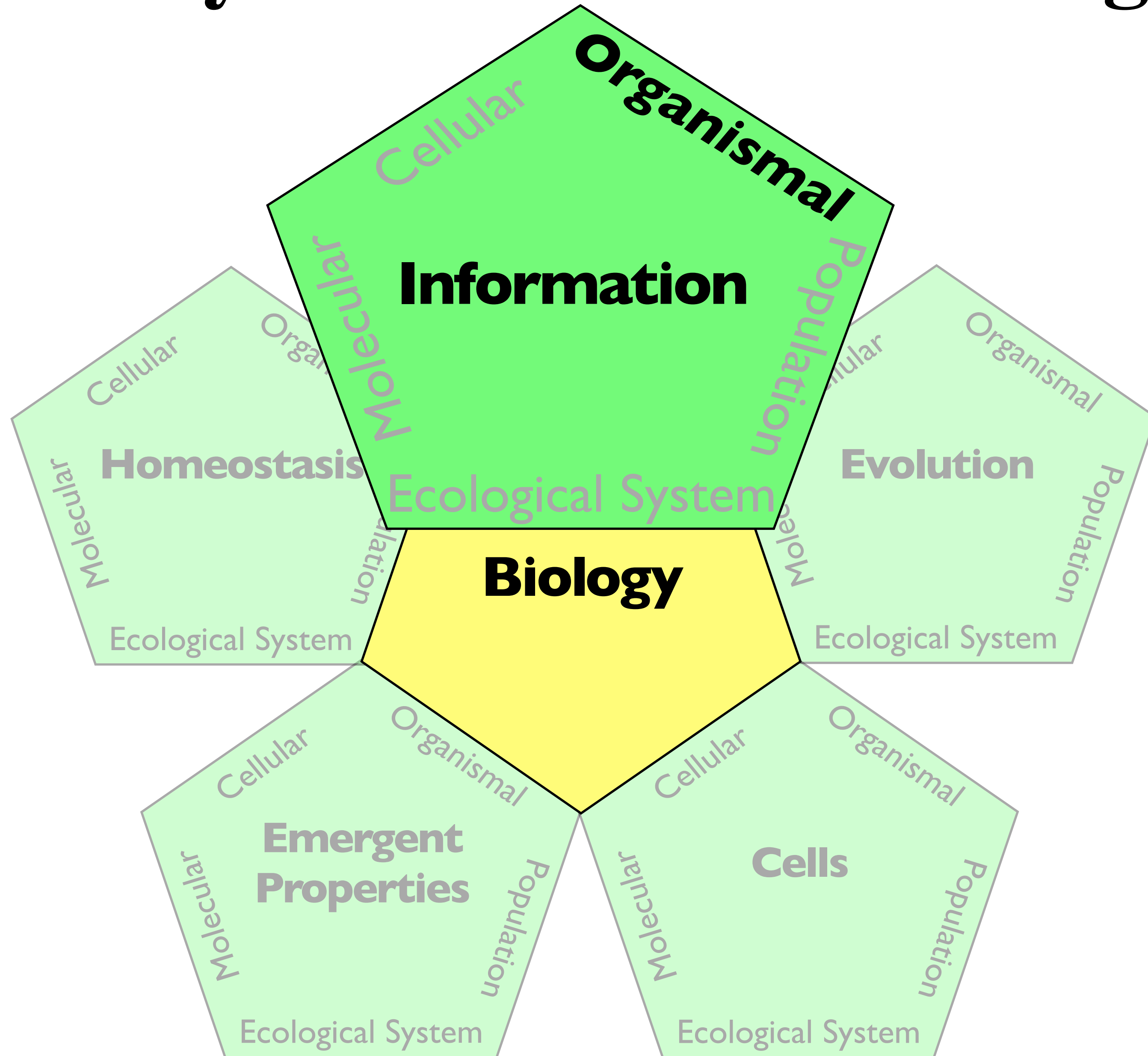

Five by Five Matrix of Biology

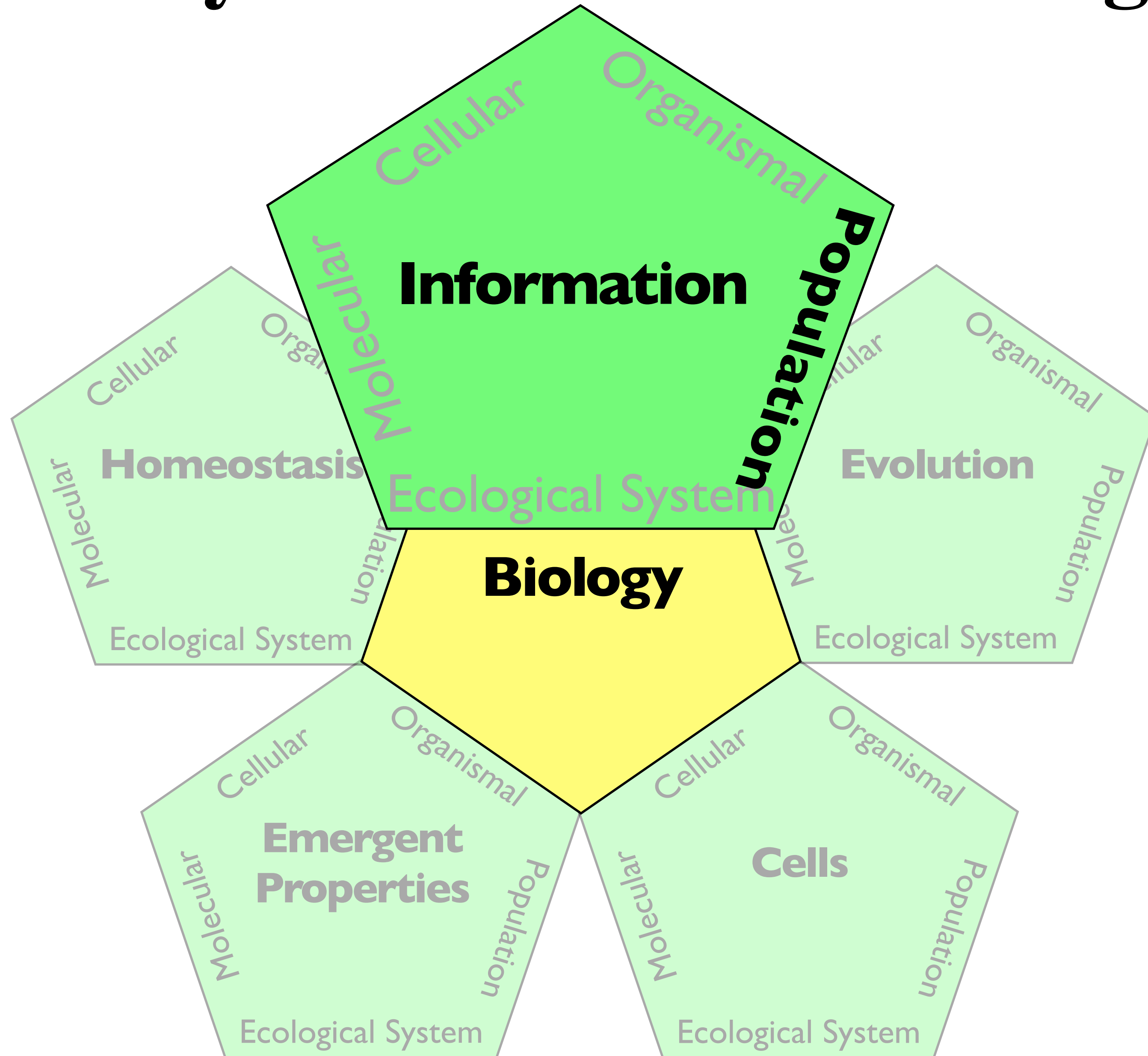

Five by Five Matrix of Biology

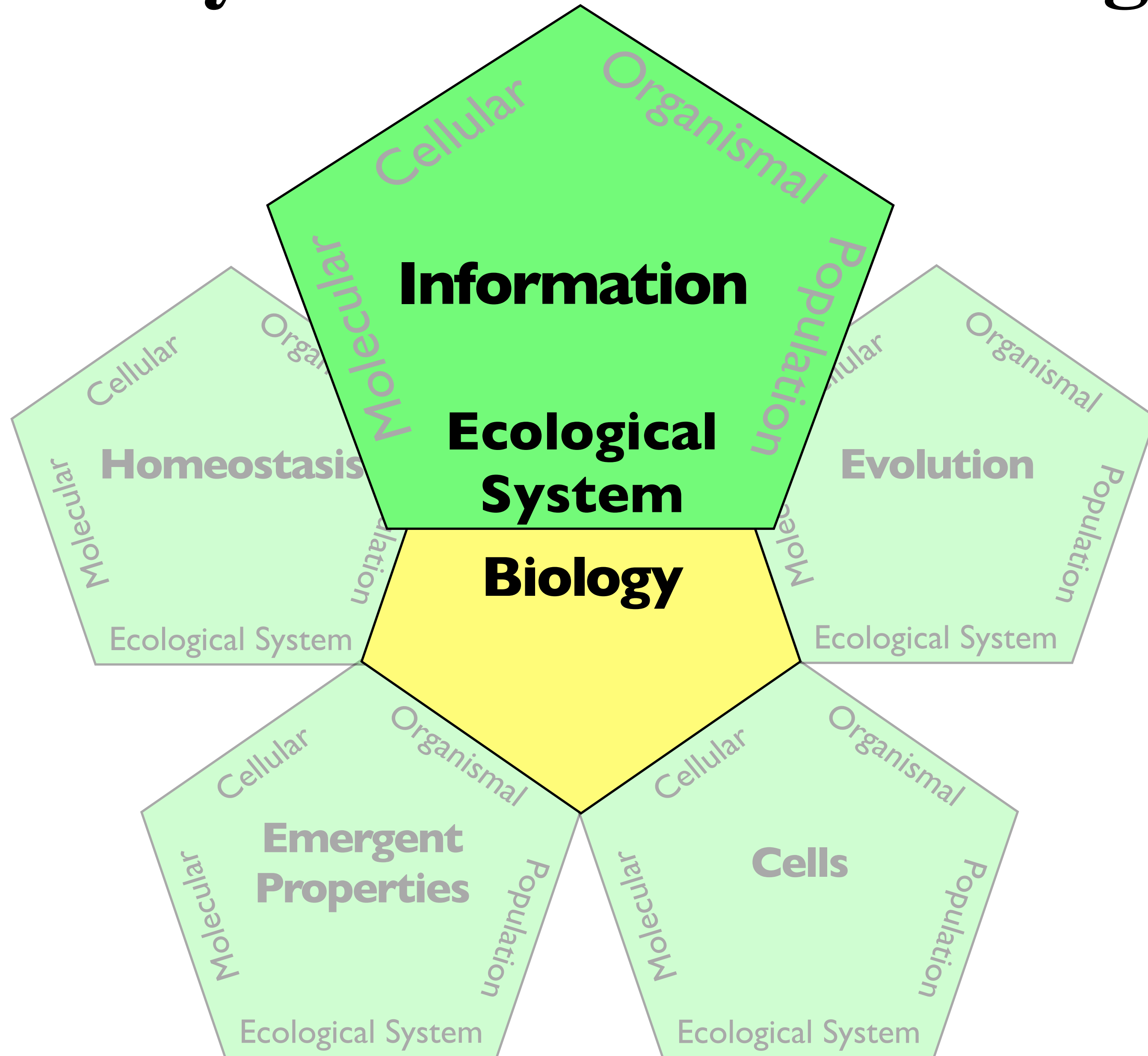

Five by Five Matrix of Biology

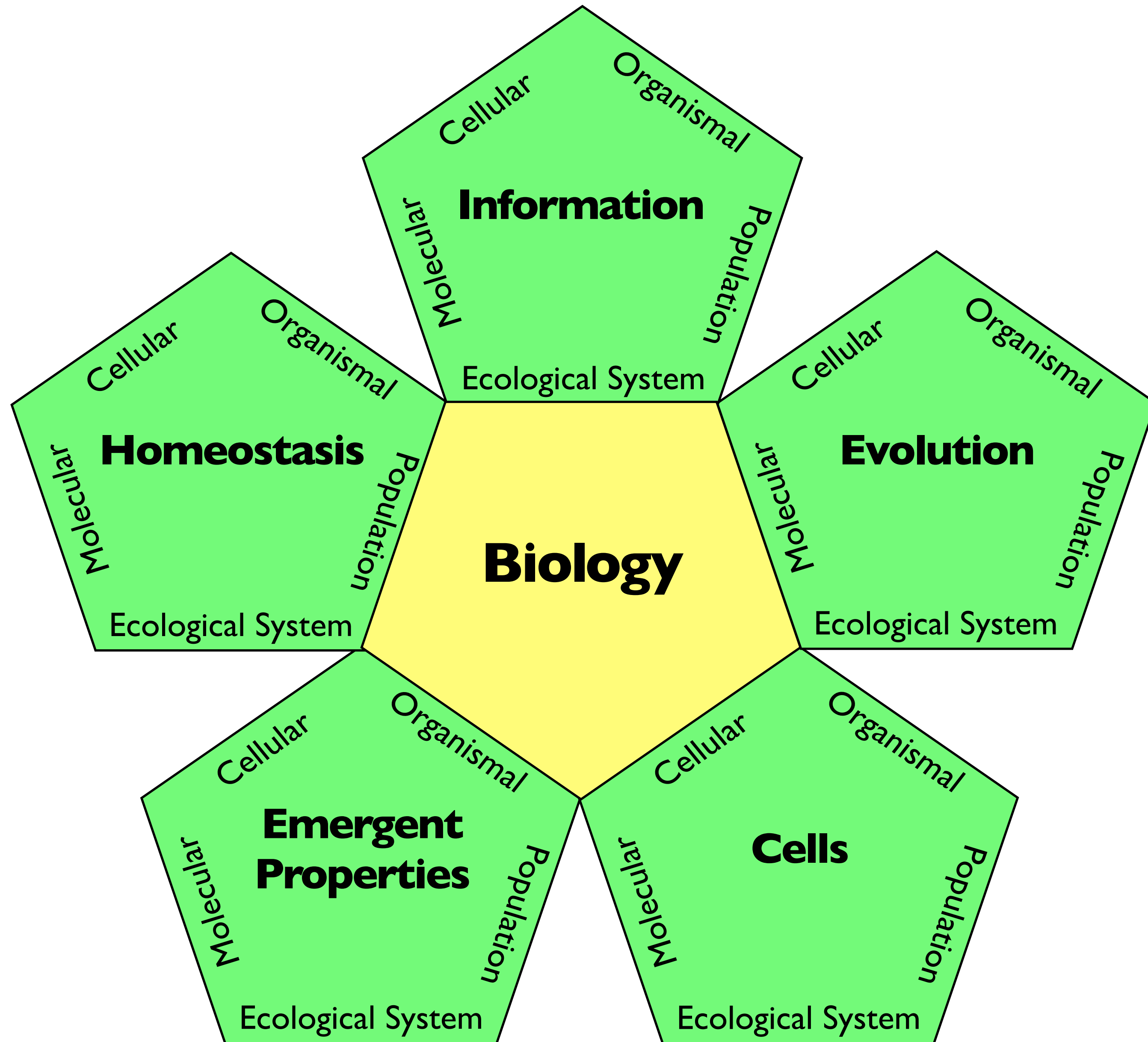

BioMath Explorations

BioMath Exploration 6.3

How can you fit
exponential curves to data?

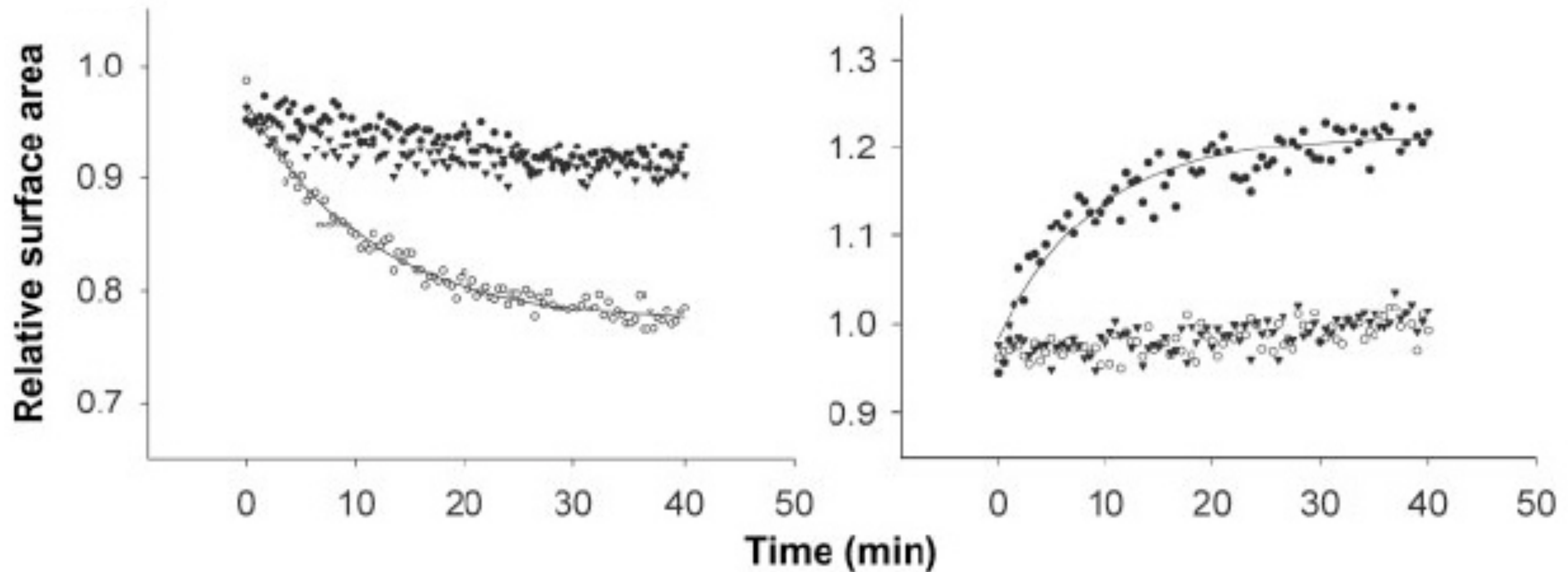

Ethical, Legal and Social Implications



Are religion and evolution compatible?

Is science possible if you are uncertain about what is true?

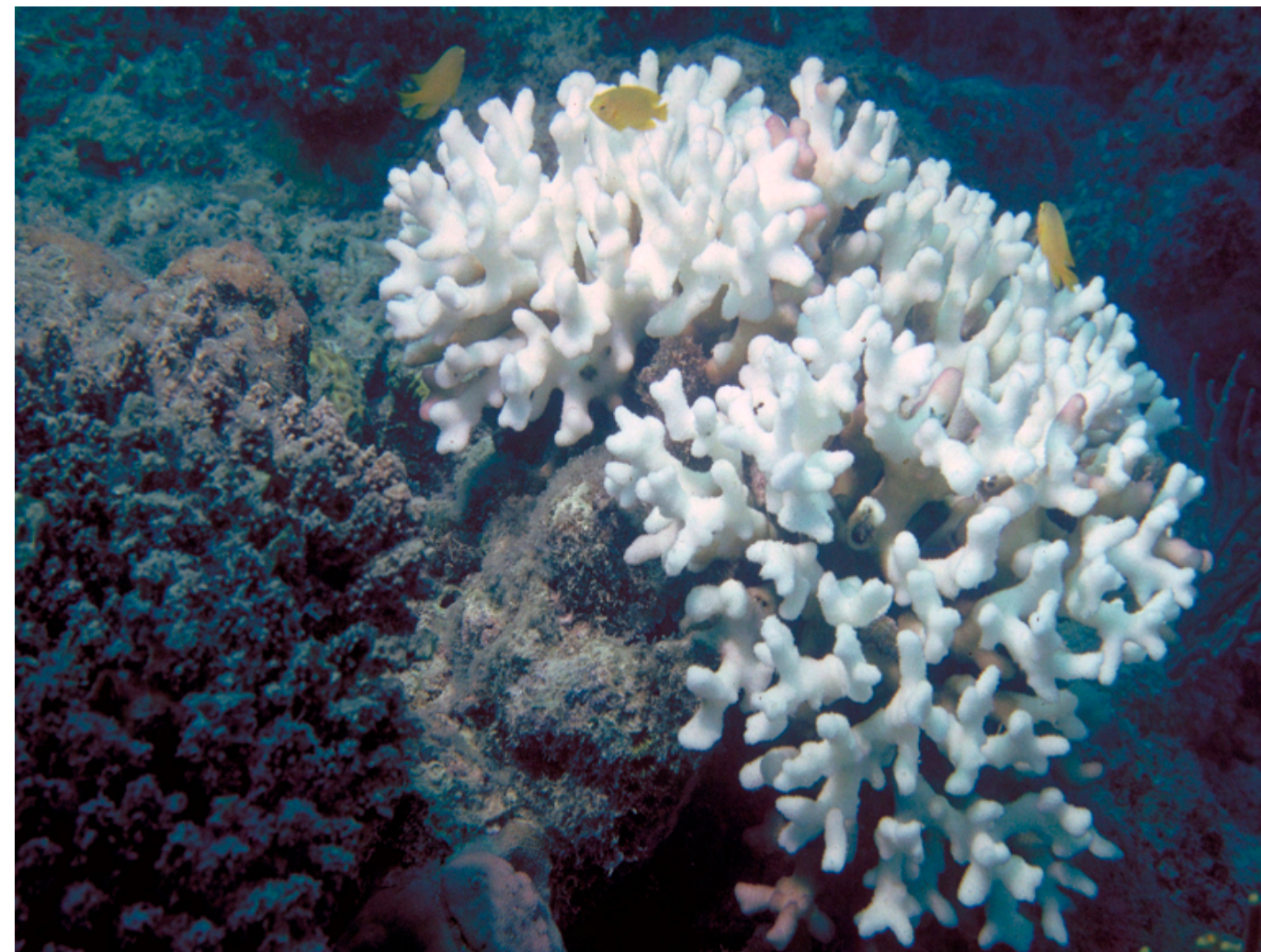

Does basic biology have any impact on the real world?

Who owns your DNA?

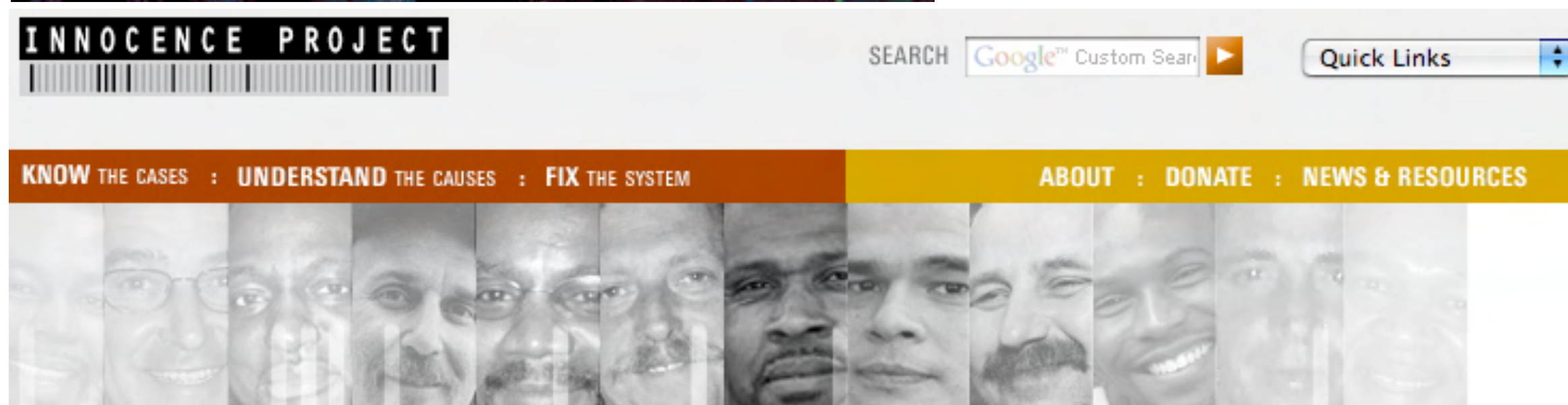

Did my students learn less content?

Student Content Questions

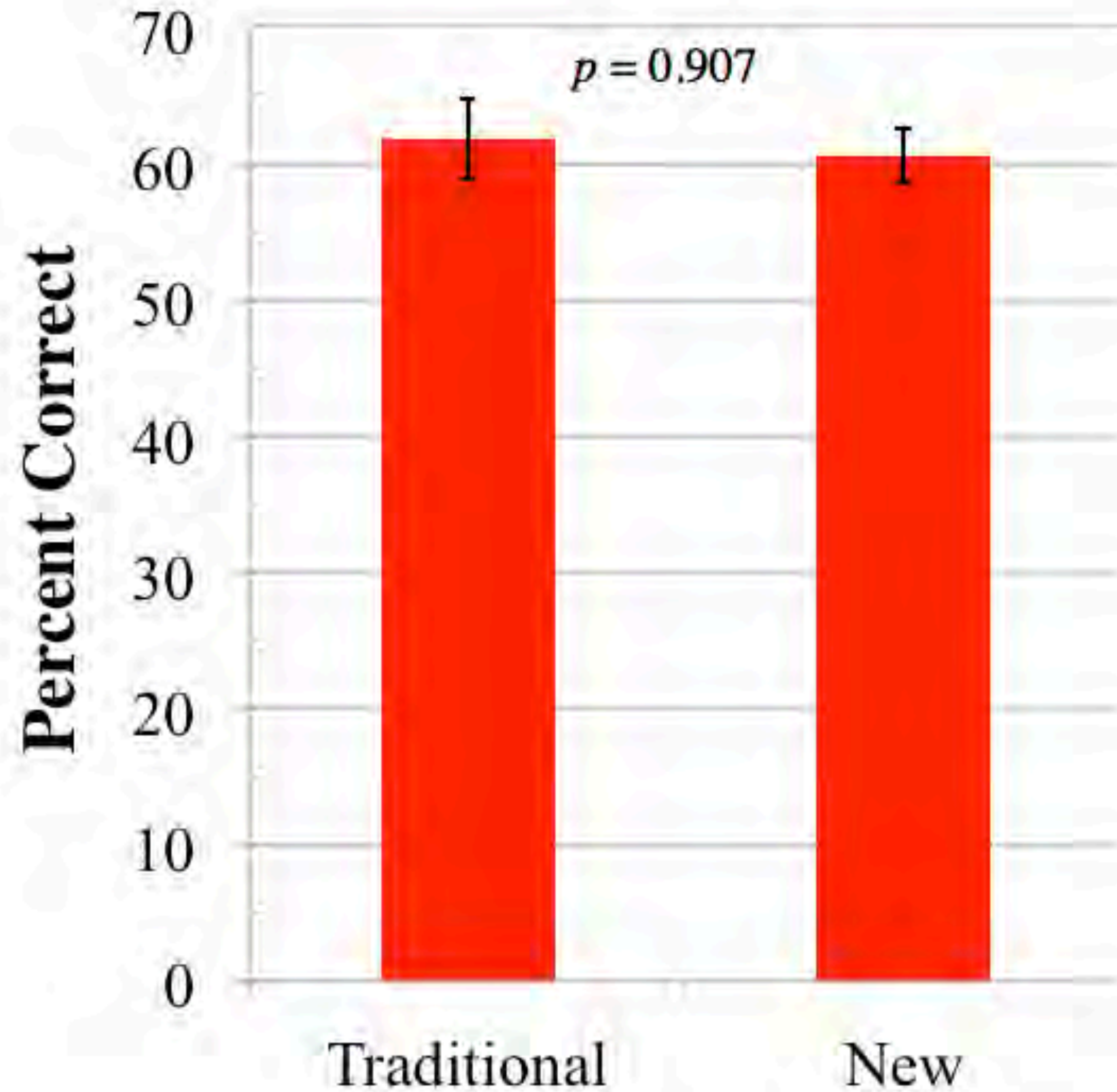

+/- SEM

Student Content Assessment

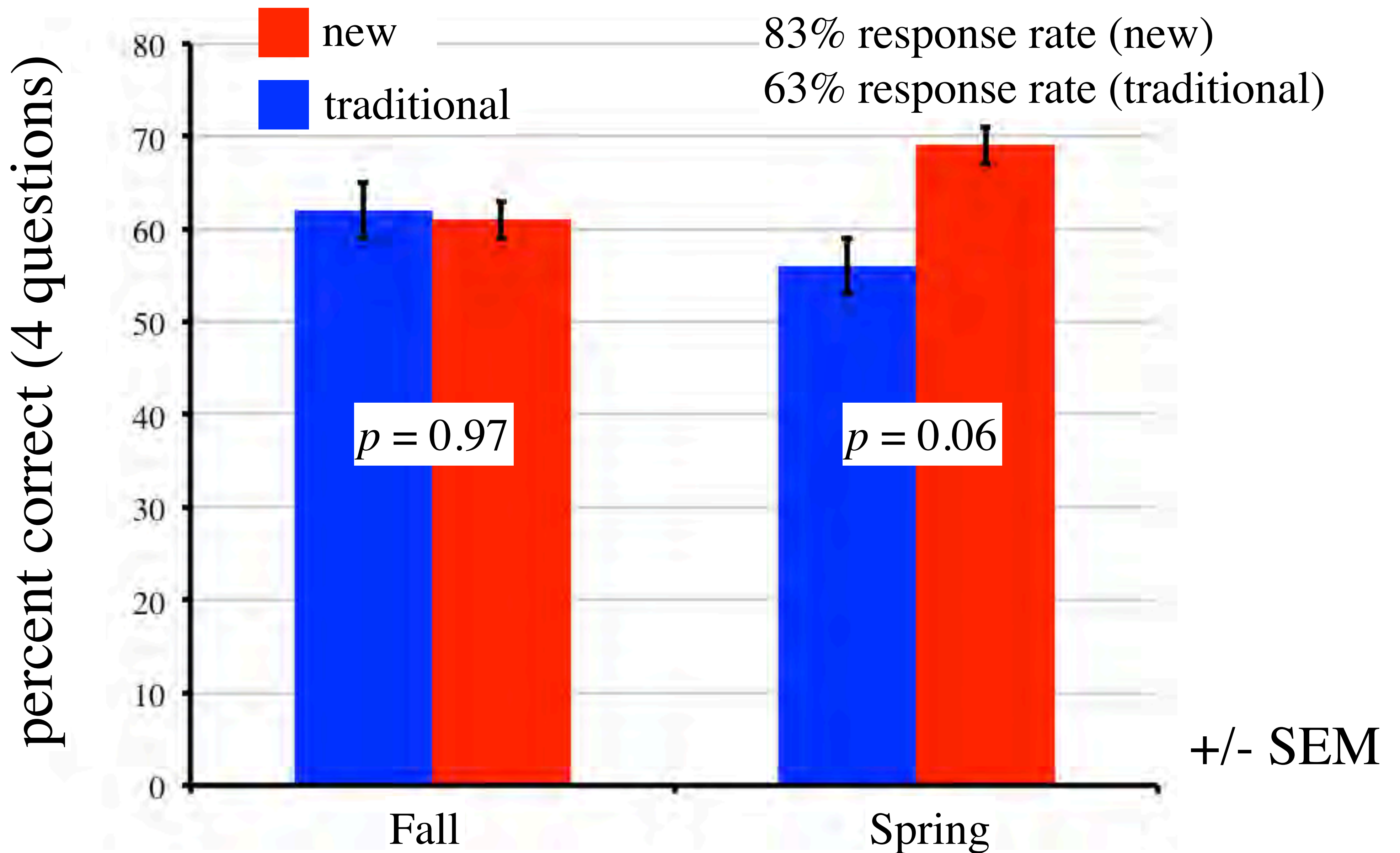

Can my students analyze data better?

Student Skills Assessment

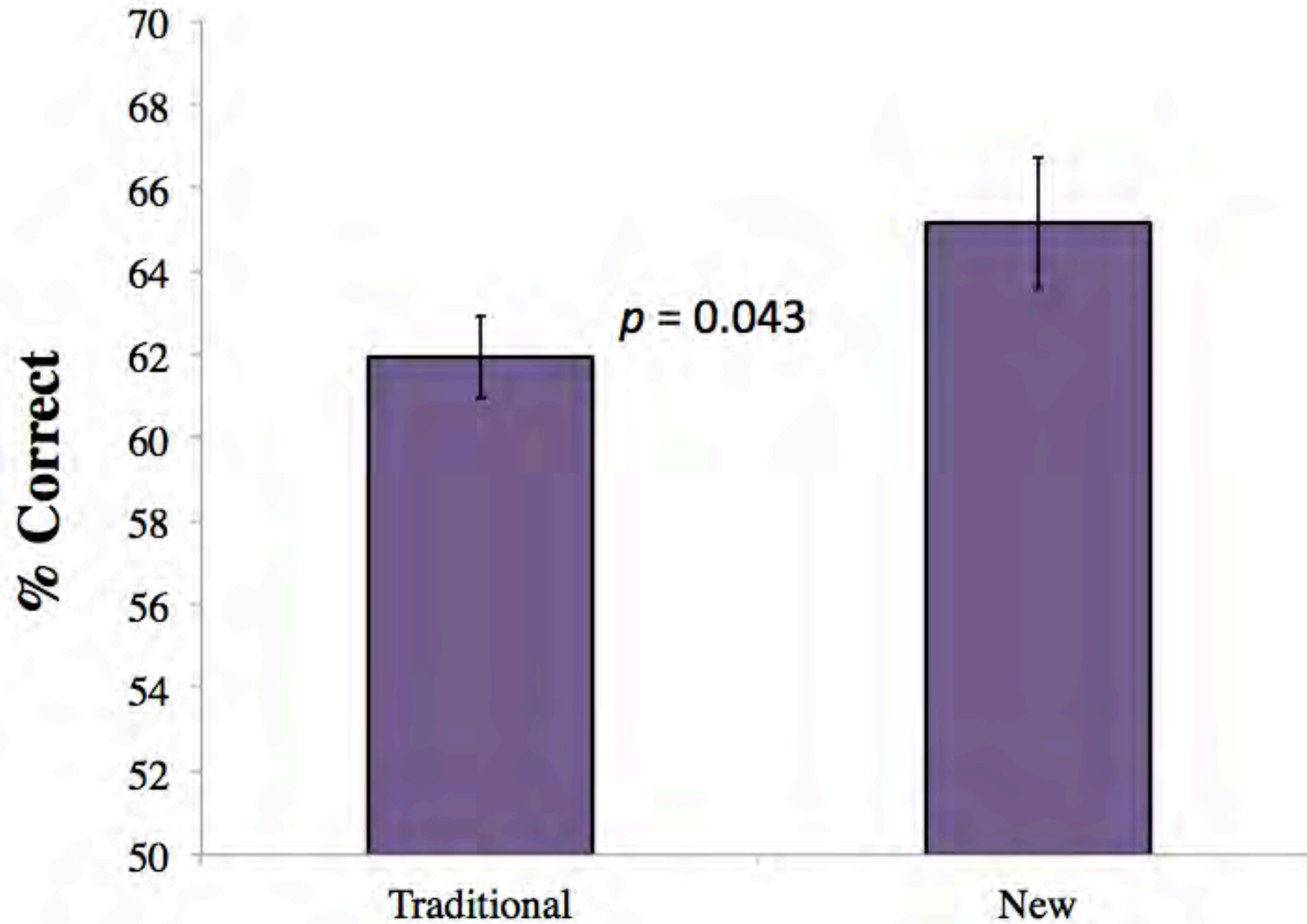

Student Skills Assessment

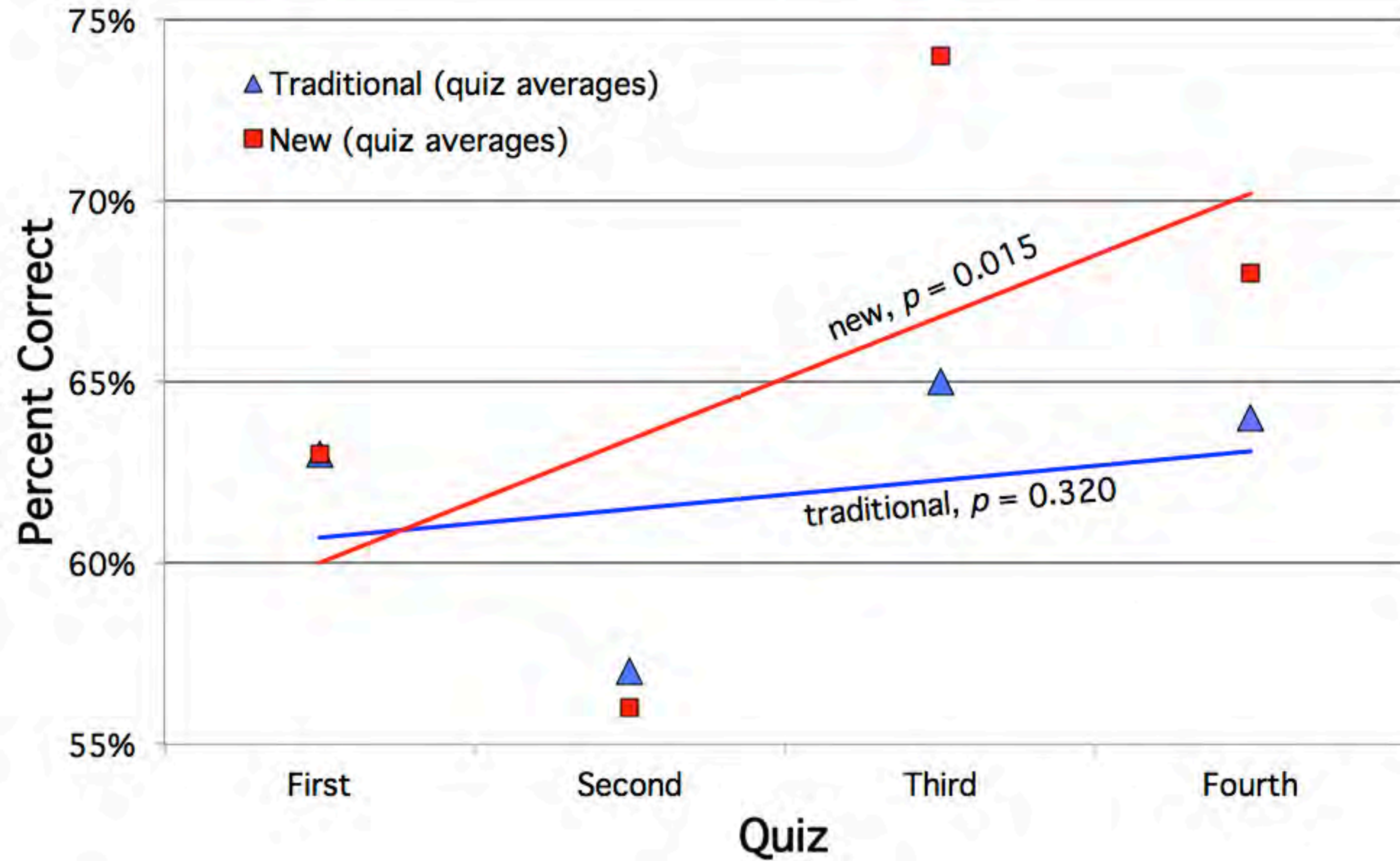

**What did my students think about
this approach to intro bio?**

“The method of learning, placing emphasis on the interpretation of data, has helped me not only in this class, but also in others.”

anonymous student course evaluation, Dec. 2010

“I found it much more beneficial using this approach compared to straight memorization. It allowed me to gain interpretation skills I was lacking before.”

anonymous student course evaluation, Dec. 2010

“The data-driven approach is brilliant. It alleviates the issues that I’ve always had of asking, ‘How do we know that? What’s the supporting data?’ ”

anonymous student course evaluation, Dec. 2010

“Emphasis on big picture and understanding how to pull information from real data was an easier and more beneficial format than memorization of facts (which used to be a struggle for me).”

anonymous student course evaluation, Dec. 2010

Why bother changing?

National Recognition of Need to Change

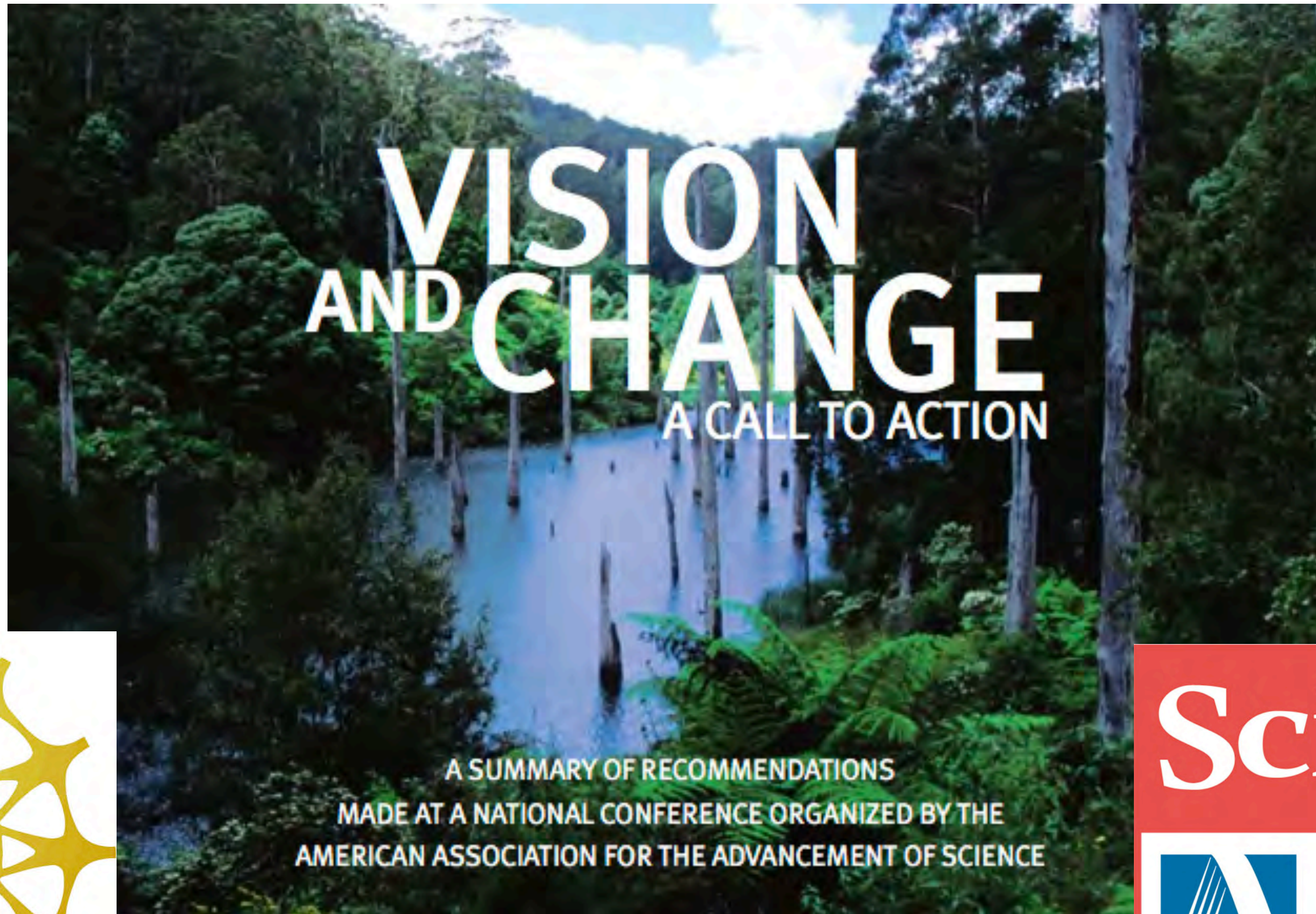

AP Biology is Changing to Match Our Design

 AP[®] BIOLOGY

Curriculum Framework
2012–2013

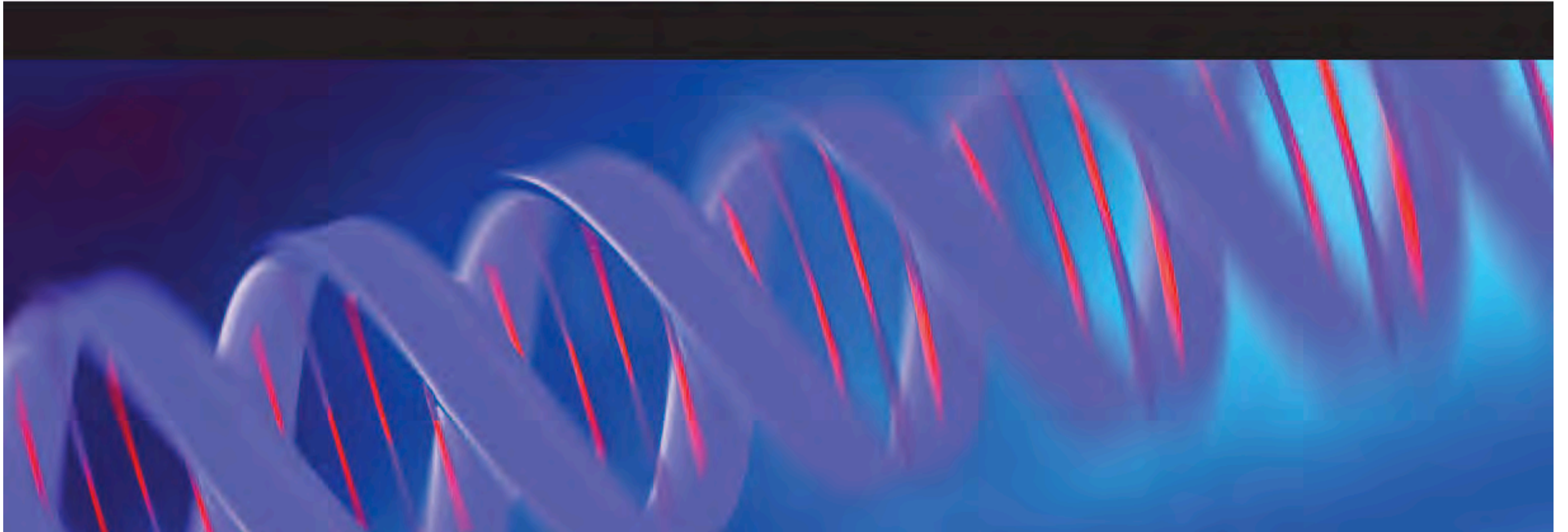

Acknowledgements

Faculty: Laurie Heyer, Jeff Poet, Todd Eckdahl, Karmella Haynes, Pat Sellers, Mark Barsoum

Students: Romina Clemente, Clif Davis, A.J. Grant, Mary Gearing, Kin Lau, Olivia Ho-Shing, Shamita Punjabi, Eric Sawyer, Ashley Schooner, Siya Sun, Shashank Suresh, Bryce Szczepanik, Leland Taylor, Annie Temmink, Alyndria Thompson, Will Vernon, Oyinade Adefuye, Will DeLoache, Jim Dickson, Andrew Martens, Amber Shoecraft, Mike Waters, Jordan Baumgardner, Tom Crowley, Lane Heard, Nick Morton, Michelle Ritter, Karen Acker, Bruce Henschen, Jessica Treece, Matt Unzicker, Amanda Valencia, Lance Harden, Sabriya Rosemond, Samantha Simpson, Erin Zwack, Marian Broderick, Adam Brown, Trevor Butner, Lane Heard, Eric Jessen, Kelley Malloy, Brad Ogden, Kelly Davis, Alicia Allen, James Barron, Robert Cool, Kelly Davis, Will DeLoache, Erin Feeney, Andrew Gordon, John Igo, Aaron Lewis, Kristi Muscalino, Madeline Parra, Pallavi Penumetcha, Karlesha Roland, Max Win, Xiao Zhu, Kristen DeCelle, Matt Gemberling, Oscar Hernandez, Andrew Drysdale, Nick Cain, Tamar Odel, and Jackie Ryan.

The Duke Endowment, NSF, HHMI
Genome Consortium for Active Teaching (GCAT)
Davidson College James G. Martin Genomics Program
MWSU SGA, Foundation & Summer Research Institute



How did I test student learning?

Four Exams Per Semester

8 pts.

9) Limit your answers to a maximum of **2 sentences for each part.**

a) Explain why it is adaptive for each eukaryotic organelle to be composed of a different lipid composition. Use data to support your answer.

Each one has a particular surface area to volume ratio and different lipids have different bending capacity. Rigid lipids produce larger volumes while relaxed lipids produce bends and small volumes inside membranes.

Lipid Name	Rat Liver ER ^a	Rat Liver Plasma Membrane ^a	Rat Liver Golgi ^a	Mouse Skin plasma membrane ^b	Yeast Inner Mitochondria ^b	Yeast Outer Mitochondria ^b	Yeast Inner Nucleus ^b
phosphatidylcholine	58	39	50	43.0	38.4	45.6	44.6
phosphatidylethanolamine	22	23	20	16.1	24.0	32.6	26.9
sphingomyelin	3	15	8	12.2	0	0	0
phosphatidylinositol	10	8	12	7.6	16.2	10.2	15.1
phosphatidylserine	3	9	6	6.4	3.8	1.2	5.9
phosphatidic acid	0	0	0	0.0	1.5	4.4	2.2
cholesterol	n.d.	n.d.	n.d.	13	—	—	—
cholesterol or diphenylidylglycerol	n.d.	n.d.	n.d.	—	16.1	9.9	1.0

^a from Germl van Meer, 1998, Table 1.
^b from Orientations of Proteins in Membranes, 2010, <http://opm.phar.umich.edu/data/ptg/>.
 n.d., not determined.

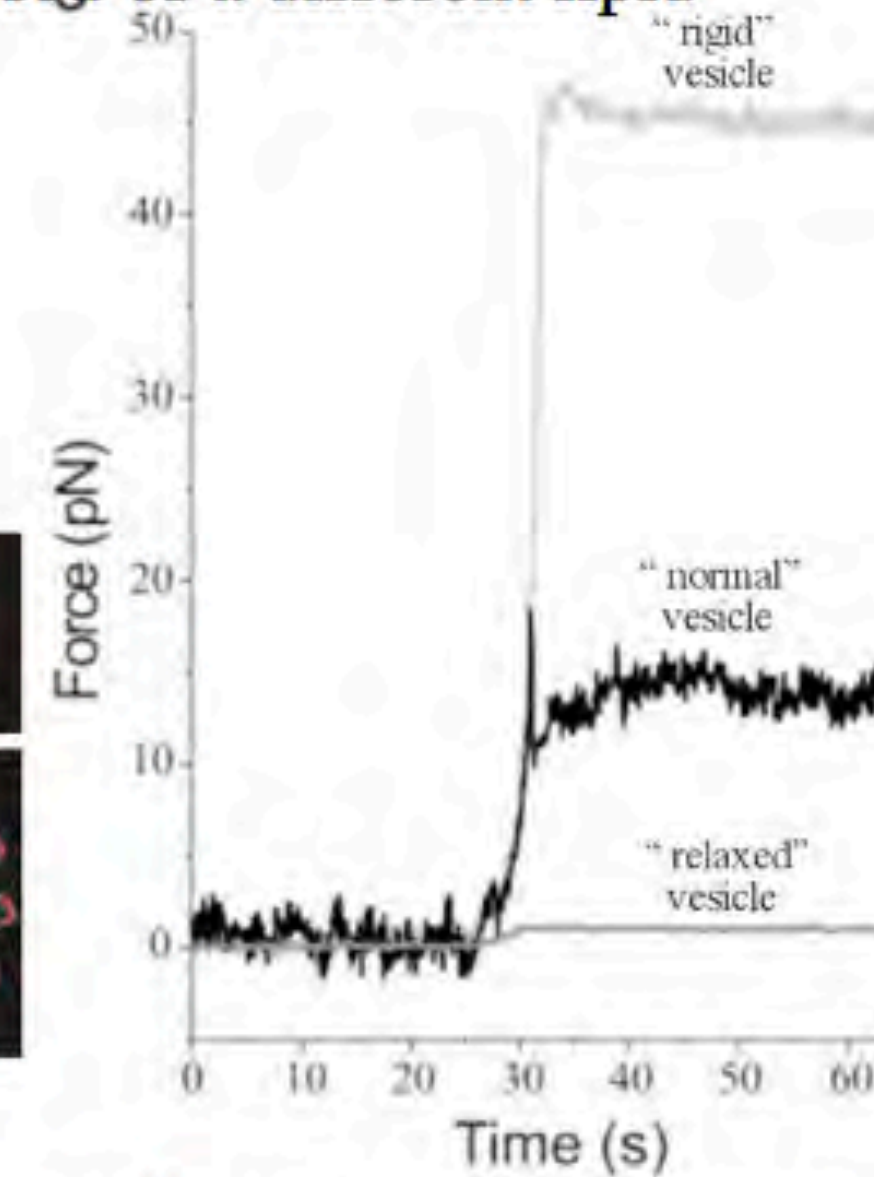
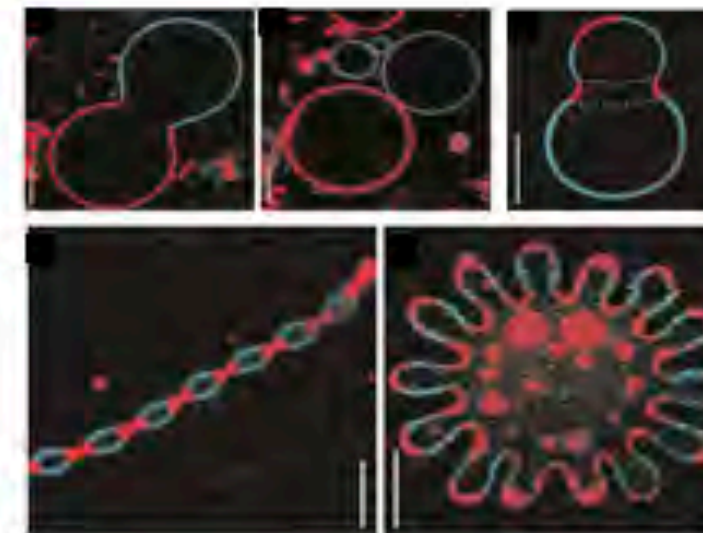

b) Would you predict that the secretory vesicles containing epinephrine would contain more rigid lipids, or flexible lipids? Use data to support your answer.

relaxed due to large surface area to volume ratio

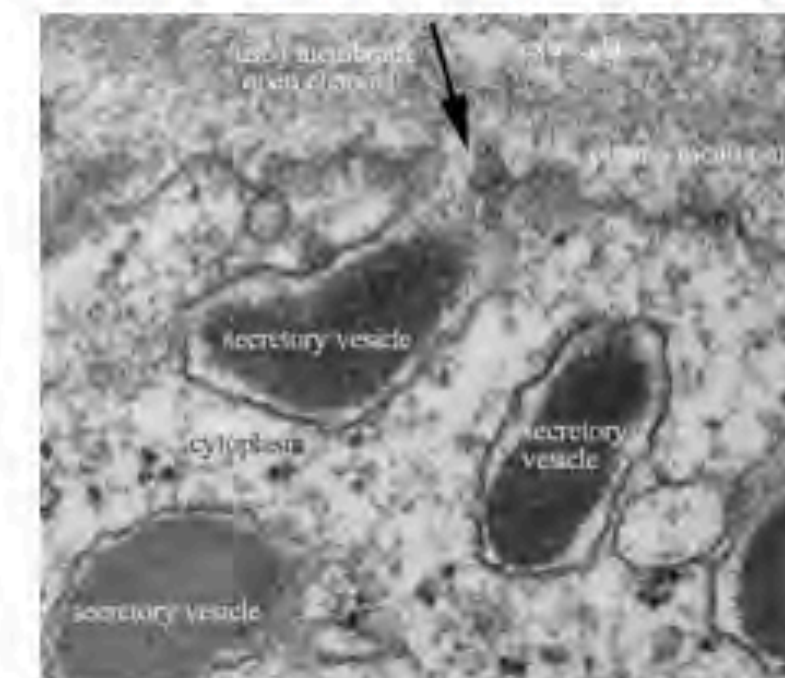

Data Gallery for Answers

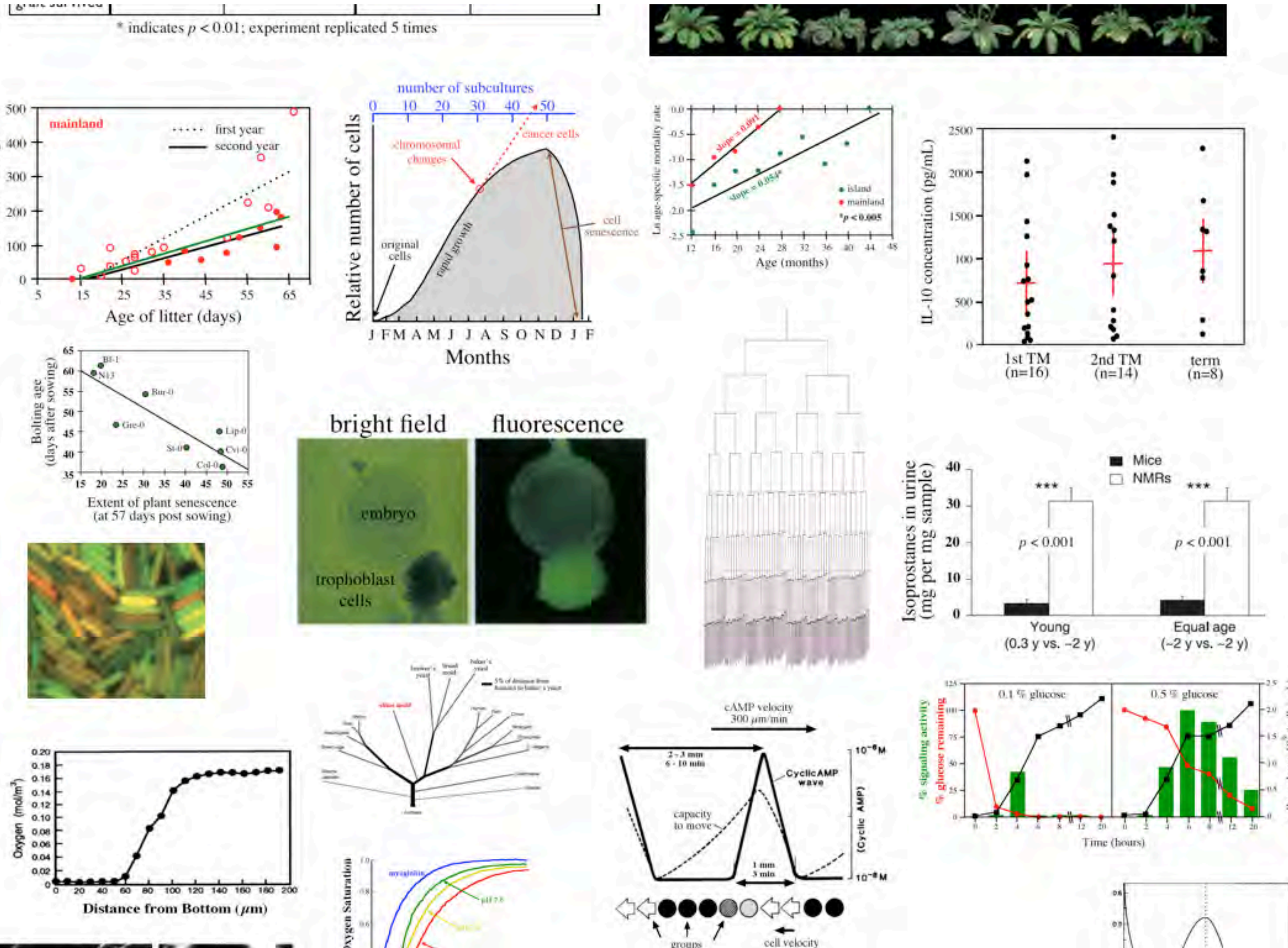

**When did the students feel they
were learning something
different than in high school?**

Table of Contents

Chapter 7 Evolution at the Cellular Level

7.1: How are new species formed? Discover how genomes can change dramatically to produce new species.

BME 7.1: What information is in a dot plot? Discover how to construct and interpret a dot plot for comparing whole genomes.

ELSI 7.1: Are GMOs safe?

7.2 Why doesn't your stomach digest itself? Analyze experimental results showing that eukaryotes evolved a shared mechanism to retain proteins inside the endoplasmic reticulum.

BME 7.2: Cause or effect? Explore the meaning of correlation, and how it is quantified.

7.3 Why do my allergies get worse each year? Determine that B cells evolve in days to produce stronger immune responses.

ELSI 7.2: Banning PB&J: How far should a society go to protect the rights of an individual?

7.4 Why are corals dying around the world? Realize that species can coevolve as symbionts and become interdependent.

BME 7.3: Can you predict coral bleaching? Evaluate the fit and predictive ability of a trendline.

Table of Contents

Chapter 17 Emergent Properties at the Cellular Level

17.1 Do unicellular species have to work solo? Realize that microbes use quorum-sensing, biofilms and communal behavior to enhance their functions.

17.2 How can changes in two cells affect an entire plant? Appreciate how guard cells change their shape to regulate plant gas exchange through stomata.

BME 17.1: Can local decisions have global effects? Model the opening of stomata using a simulation of local rules.

17.3 How do brain cells store memories? Discover how long-term memories are formed by analyzing classic experiments on *Aplysia* learning.

ELSI 17.1: If pills could make you remember or forget, would you take them?

17.4 Does the genome allow random actions by cells? Learn how random movements of molecules determine cell phenotypes which can be transmitted across generations.

BME 17.2: What is chaos?

Table of Contents

Chapter 22 Homeostasis at the Cellular Level

22.1 Why is paraquat used in America but illegal in Europe? **Analyze classic experiments to deduce how light energy is captured by plant cells.**

22.2 How does Brazil's rainforest affect Greenland's glaciers? **Determine how carbon dioxide is fixed by photosynthetic cells into biological molecules.**

ELSI 22.1: How do you compromise when a policy hurts one country but helps another?

22.3 Is there anywhere on earth devoid of life? **Explore inhospitable niches where microbes have evolved homeostatic mechanisms to survive harsh conditions.**

Student Skills Assessment

